



PHOENIX MECANO

EN Assembly instruction
Lifting column LC1000C

Content

1	Declaration of incorporation LC1000C4
2	General notes on these assembly instructions5
3	Liability / Warranty6
3.1	Liability6
3.2	Product monitoring6
3.3	Language of the operating instructions6
3.4	Copyright7
4	Use / Operating personnel8
4.1	Intended use8
4.2	Non-intended use8
4.3	Reasonably foreseeable misapplications8
4.4	Who may use, assemble and operate this lifting column?8
5	Safety9
5.1	Safety instructions9
5.2	Special safety instructions9
5.3	Safety sign10
6	Product information11
6.1	Mode of operation11
6.1.1	Variants of the power supply11
6.1.2	Variants of force / speed11
6.2	Geometry dimensions12
6.3	Overview of connector/connector options13
6.4	Technical data14
6.5	Overview of the lifting column15
6.6	Performance diagrams Fehler! Textmarke nicht definiert.
6.6.1	Current consumption16
6.6.2	Speeds18
6.6.3	Weight data20
6.7	First commissioning21
6.7.1	General21
6.7.2	Single drives21
6.7.3	Synchronization system22
6.7.4	Operation with multiple voltage sources25
6.8	Operating modes25
6.8.1	General25
6.8.2	Normal operation25
6.8.3	Initialization mode26
6.8.4	Compensation mode26
6.8.5	Emergency operation mode27
6.9	Fine adjustment of the installation dimension28
7	Phases of life29
7.1	Scope of delivery of the lifting column29
7.2	Transport and storage29
7.3	Important notes on installation and commissioning29
7.3.1	Synchronous operation of electric cylinders and lifting columns30

7.3.2	Different heights	30
7.3.3	Parallel alignment	30
7.3.4	Crooked connecting plates	30
7.3.5	The ideal structure	31
7.3.6	Load distribution	32
7.4	Mounting	32
7.5	Maintenance	32
7.6	Cleaning	32
7.7	Disposal and take-back	33
8	Appendix: Connection diagrams	34

1 Declaration of incorporation LC1000C

in the sense of the Machinery Directive 2006/42/EC, Annex II, 1.B for partly completed machinery.

Manufacturer:

Phoenix Mecano Solutions AG
Hofwisenstrasse 6
CH-8260 Stein am Rhein

confirms that the said product

Product Name: *LC1000C*

Type designation: *LC1000C*

Commercial designation: *LC1000C*

Function: Electromotive retraction and extension of the inner profile to generate a
Linear motion

the requirements of an **incomplete machine** according to the EC Machinery Directive 2006/42/EC complies.

The following essential requirements of the Machinery Directive 2006/42/EC according to Annex I are applied and fulfilled:

1.1.5.; 1.3.2.; 1.3.3.; 1.3.4.; 1.3.7.; 1.5.1.; 4.1.2.1.; 4.1.2.3.

It also declares that the specific technical documentation has been prepared in accordance with Annex VII, Part B.

It is expressly declared that the **partly completed machinery** complies with all relevant provisions of the following EC Directives:

2011/65/EU Directive 2011/65/EU of the European Parliament and of the Council of 8 June 2011 on the restriction of the use of certain hazardous substances in electrical and electronic equipment

IEC 61000 IEC 61000-6-2:2016, EN 61000-6-2:2019, IEC 61000-6-4:2018, EN 61000-6-4:2007+A1:2011

Phoenix Mecano Solutions AG undertakes to transmit the technical documentation on the partly completed machinery in electronic form to the national authorities upon justified request.

Commissioning is prohibited until the machine, into which this incomplete machine is installed, complies with the provisions of EC Directive 2006/42/EC.

Before being placed on the market, this must comply with the CE directives, including documentation.

2 General notes on these assembly instructions

These assembly instructions are only valid for the lifting column described and are intended as documentation for the manufacturer of the end product into which this incomplete machine is integrated.

We expressly draw your attention to the fact that the manufacturer of the end product must prepare operating instructions for the end customer which contain all the functions and hazard warnings of the end product.

This also applies to installation in a machine. Here, the machine manufacturer is responsible for the corresponding safety devices, inspections, monitoring of any crushing and shearing points that may occur, and documentation.

These assembly instructions will assist you,

- Avoid dangers,
- Prevent downtime,
- and to ensure or increase the service life of this product.

Danger notes, safety regulations and the information in these installation instructions must be observed without exception.

The assembly instructions must be read and applied by every person who works with the product.

Commissioning is prohibited until the machine complies with the provisions of EC Directives 2006/42/EC (Machinery Directive). Before being placed on the market, it must comply with the CE directives, also in terms of documentation.

We expressly draw the attention of the further user of this incomplete machine / partial machine / machine parts to the obligation to extend and complete this documentation. In particular, when installing or mounting electrical elements and / or drives, a CE Declaration of Conformity must be drawn up by the subsequent user, as this Declaration of Incorporation was expressly drawn up for the partly completed machine itself and automatically loses its validity through integration / installation in a machine.

3 Liability / Warranty

3.1 Liability

Phoenix Mecano Solutions AG accepts no liability for damage or impairment resulting from structural modifications by third parties or modifications to the protective devices on this lifting column. Phoenix Mecano Solutions AG accepts no liability for spare parts that have not been tested and approved by Phoenix Mecano Solutions AG. The EC declaration of incorporation will otherwise become invalid.

Safety-relevant equipment must be checked regularly for function, damage and completeness.

We reserve the right to make technical changes to the lifting column and changes to these assembly instructions.

Advertising, product brochures for sales activities, public statements or similar announcements may not be used as a basis for the suitability and quality of the product, detailed technical advice is therefore expressly recommended. Claims against Phoenix Mecano Solutions AG for the deliverability of previous versions or adaptations to the current version status of the lifting column cannot be asserted.

If you have any questions, please specify the information on the nameplate.

Our address:

Phoenix Mecano Solutions AG
Hofwisenstrasse 6
CH-8260 Stein am Rhein

Tel.: +41 (0)52 742 75 00

Fax: +41 (0)52 742 75 90

3.2 Product monitoring

Phoenix Mecano Solutions AG offers you products at the highest technical level, adapted to current safety standards. Please inform us immediately of any repeated failures or malfunctions.

3.3 Language of the operating instructions

The original version of these assembly instructions was written in the official EU language (German) of the manufacturer of this partly completed machine. Translations into other languages are translations of the original version; the legal requirements of the Machinery Directive apply.

3.4 Copyright

Individual reproductions, e.g. copies and printouts, may only be made for private/company internal use. The production and distribution of further reproductions is only permitted with the express permission of Phoenix Mecano Solutions AG. It is expressly advised not to make copies of documents relevant to the product - it is always better to download the latest version of the documents from *phoenix-mecano.ch* in order to prevent the circulation of outdated documents. The user is responsible for compliance with the legal regulations and may be held liable in case of misuse. The copyright of these assembly instructions belongs to Phoenix Mecano Solutions AG.

4 Use / Operating personnel

4.1 Intended use

The lifting column is to be used exclusively for the adjustment of guided components or other adjustment tasks of a comparable nature. The lifting column must not be used in potentially explosive atmospheres or in direct contact with foodstuffs, pharmaceutical or cosmetic products. Catalog specifications, the contents of these assembly instructions and/or conditions specified in the order must be taken into account. The values specified in these assembly instructions are maximum values and must not be exceeded.

4.2 Use not in accordance with the intended purpose

"Unintended use" is defined as use contrary to the instructions given in chapter 4.1 *Intended use*. In the event of improper use, improper handling and if this lifting column is used, installed or handled by untrained personnel, hazards may arise from this lifting column for the personnel. Moving persons and animals with this lifting column, as an example of improper use, is prohibited. In the event of improper use, the liability of Phoenix Mecano Solutions AG and the general operating permit for this lifting column shall expire.

4.3 Reasonably foreseeable misapplications

- Overload of the device due to ground or exceeding of the max. permissible duty cycle.
- Use in environments outside the specified IP protection class
- Use in environment with high humidity > dew point
- Use in rooms with explosive atmosphere according to ATEX directive
- Operation in case of damage to the power supply line, the housing, the motor cable, the hand switch or other control lines (PLC, PC, etc.) → Attention: Accessories (power supply, hand switch, etc.) have protection class IP40
- Load with insufficient mounting or insufficient fastening
- Driving on block (stop, collision with non-movable components)
- Use in applications with laterally acting forces and moments
- Hazards due to lack of consideration of different states and failure modes, such as the no-energy state.

4.4 Who may use, assemble and operate this lifting column ?

Persons who have read and understood the assembly instructions in their entirety may use, assemble and operate this lifting column. The responsibilities for handling this lifting column must be clearly defined and observed.



Phoenix Mecano Solutions AG drives are not suitable for the following applications:

- Offshore applications
- Aircraft and other flying devices
- Nuclear power plants / nuclear power
- Explosion hazardous locations
- Locations of use at high altitude (from 2000 m a.s.l.) without additional consideration and practical tests

5 Security

5.1 Safety instructions

Phoenix Mecano Solutions AG has built this lifting column in accordance with the current state of the art and the existing safety regulations. Nevertheless, danger to persons and property can arise from this lifting column if it is used improperly or not in accordance with its intended use or if the safety instructions are not observed. Expert operation ensures high performance and availability of the lifting column. Faults or conditions which may impair safety must be rectified immediately.

Every person involved in the assembly, use and operation of this lifting column must have read and understood the assembly instructions.

This includes that you:

- understand the safety instructions in the text and
- Learn the layout and function of the various operations and uses.

The use, assembly and operation of the lifting column may only be carried out by trained personnel intended for this purpose. All work on and with the lifting column may only be carried out in accordance with these instructions. It is therefore essential that these instructions are kept close to the lifting column, ready to hand and protected.

The general, national or company safety regulations must be observed. The responsibilities for the use, assembly and operation of this lifting column must be unambiguously regulated and adhered to so that no unclear competencies arise from the point of view of safety. Before each start-up, the user must ensure that there are no persons or objects in the danger zone of the lifting column. The user may only operate the lifting column when it is in perfect condition. Any change must be reported immediately to the next responsible person.

5.2 Special safety instructions

- All work with the lifting column may only be carried out in accordance with these instructions.
- The lifting column may only be opened (installed / removed) by authorized specialist personnel. In the event of a defect in the lifting column, we recommend contacting the manufacturer or sending in this lifting column for repair.
- Before assembly, disassembly, maintenance or troubleshooting, safely disconnect the power source beforehand.
- Crushing between the mounting plate and the customer's connection must be prevented by the user.
- Proper routing of supply lines prevents hazards from this application.
- Only original accessories and original spare parts may be used.
- Possible damage due to failure of the end position cut-off, the position measuring system, the control electronics or due to nut breakage must be prevented by the downstream user by means of design.
- Potential damage from incorrect position feedback must be prevented by design.
- Possible damage caused by exceeding the maximum specified stroke due to a fault, defect or misalignment in the position measuring system must be prevented with suitable measures.
- Lateral forces or torques must not act on the lifting column.
- Additional safety devices (e.g.: wire rope, chain, etc.) must be attached to suspended loads!
- Possible failure of the limit switch or the mechanical system must be taken into account in the design. Appropriate end stops must be fitted if required. In particular, for overhead installations or tensile loads, an external extension safety device/load safety device (e.g.: wire rope, chain, etc.) must be provided.
- Only original spare parts may be used for maintenance, which may only be installed by trained specialist personnel.
- It must be ensured that no persons are in the danger zone when the load is suspended.
- Maintenance work is only permitted in an ESD-protected environment (EPA).
- Unauthorized conversions, repairs or modifications to the lifting column are not permitted for safety reasons.

- The performance data for this lifting column specified by Phoenix Mecano Solutions AG must not be exceeded (see chapter ***Fehler! Verweisquelle konnte nicht gefunden werden. Fehler! Verweisquelle konnte nicht gefunden werden.***).
- The nameplate must remain legible. The data must be retrievable at any time and without effort.
- Hazard symbols used for safety purposes indicate hazardous areas on the product.
- Safety-relevant equipment must be checked regularly, at least once a year, for function, damage and completeness.
- If the lifting column is mounted overhead, attached loads must be secured against falling by the customer. The danger area below the application must be marked in the documentation of the end product.
- If the mains cable and/or supply line and/or signal lines and/or communication lines are damaged, the lifting column must be taken out of operation immediately.

5.3 Safety sign

Warning and mandatory signs are safety signs that warn of risk or danger. Information in these assembly instructions on special hazards or situations on the lifting column must be observed; failure to do so increases the risk of accidents.



The "General requirement sign" indicates to behave attentively. Marked information in these mounting instructions is subject to your special attention. You will find important information on functions, settings and procedures. Failure to observe this information may result in personal injury, malfunctions of the lifting column or the environment.

6 Product information

6.1 Functionality

The lifting column is used to adjust guided components or other adjustment tasks of a similar type. It is driven by a low-voltage motor.

6.1.1 Power supply variants

Power supply 12 / 24 VDC



The lifting column can feed energy back to the power supply during deceleration processes, such as stopping. The amount of energy fed back and whether this occurs depends mainly on the load, the speed, the design and the set deceleration ramp. Other dependencies, such as temperature, mechanical tolerances etc. pp. also favor/inhibit this effect, but usually cannot be influenced or have only a minor influence. Likewise, for drives without self-locking, energy feedback can occur during load travel in the direction of force during travel.

Consider the energy recovery when selecting and evaluating the voltage source. For version with self-locking, usually 2kN, 4kN and 10kN in combination with the PMPS voltage supply unit, a deceleration ramp of 60% is recommended for low loads. With increase of the load, the deceleration ramp can be shortened in the direction of 100%. The use of the PMPS in versions without self-locking is not permitted.

6.1.2 Variants of force / speed

With reference to the force and speed of the LC1000C lifting column, the following different basic designs result:

Versions	Push force	Pull force	C Variant	
			No-load@24VDC	Nominal load@24VDC
Execution I	F=10'000 N push	F= 4'000 N pull	9 mm/s	≤ 8 mm/s
Execution II	F= 4'000 N push	F= 4'000 N pull	22 mm/s	≤ 19 mm/s
Execution III	F= 2'000 N push	F= 2'000 N pull	29 mm/s	≤ 27 mm/s

The values given were determined under optimum conditions and may change due to friction losses, temperature changes, general tolerances or external disturbances.

Drives of the **LC1000C** variant have an internal control, for example, to keep the speeds almost constant in different load cases, or to run at a lower speed before reaching the end positions. The speed and other parameters can be set via the CAN interface using free software and a communication cable.

6.2 Geometry dimensions

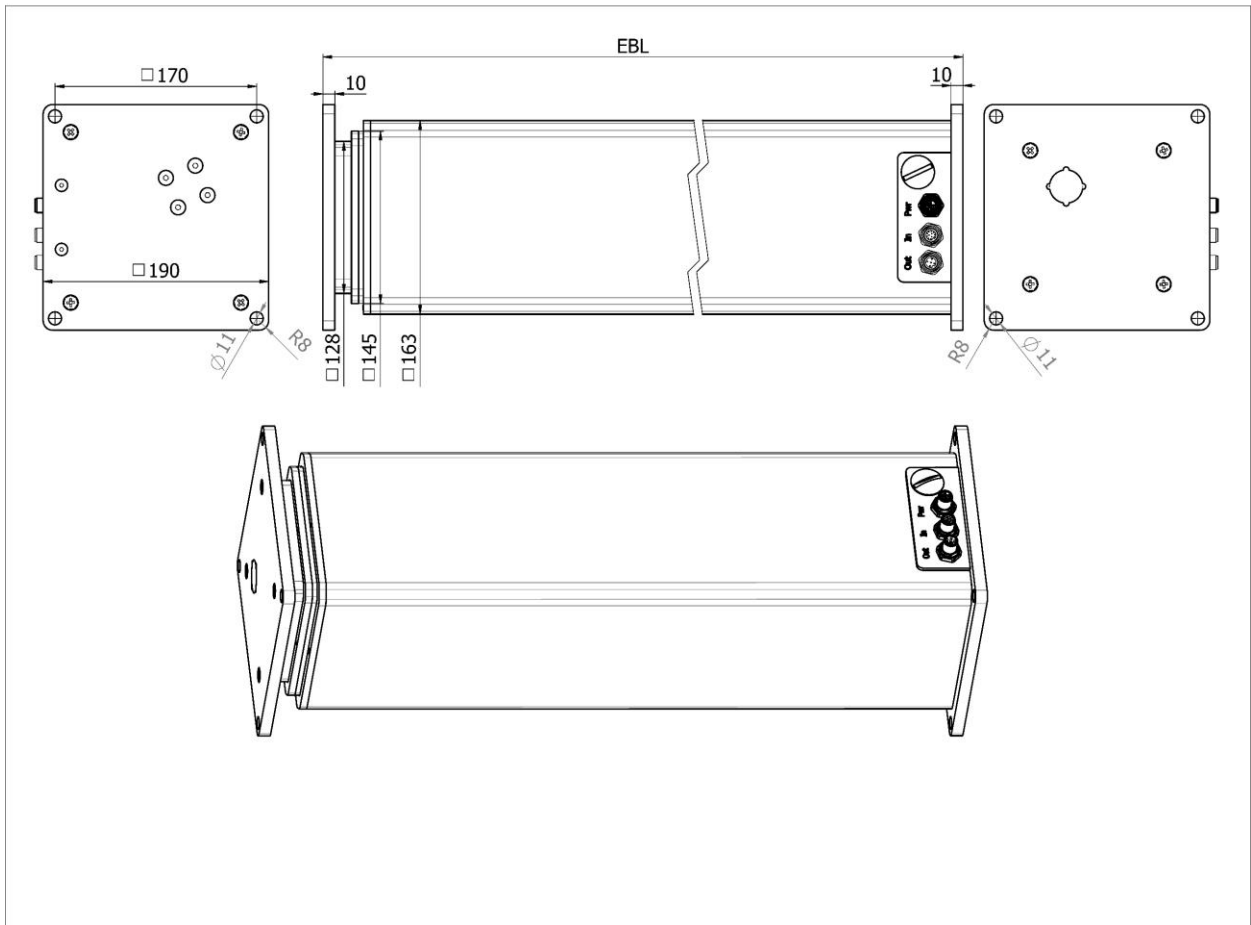

Figure 1

6.3 Overview of plug/connector options

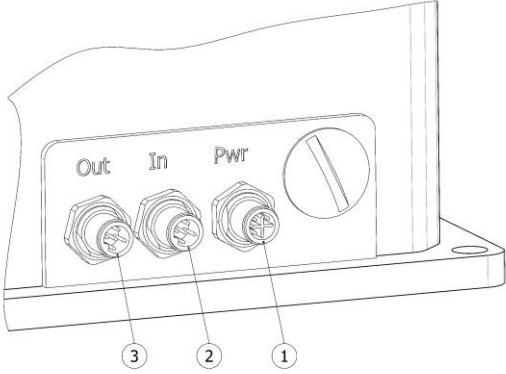

Figure 2: Master

- ① Power connector M12-3pin
- ② Signal connector M12-12pin
- ③ Signal connector M12-5pin

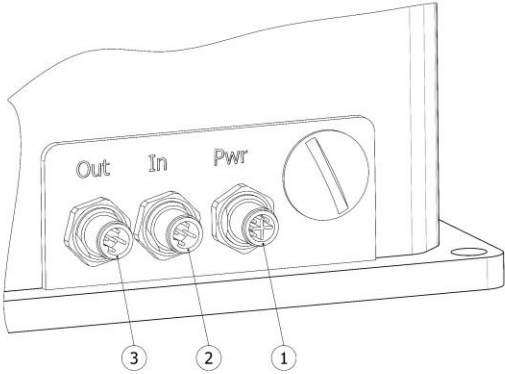

Figure 3: Slave

- ① Power connector M12-3pin
- ② Signal connector M12-5pin
- ③ Signal connector M12-5pin

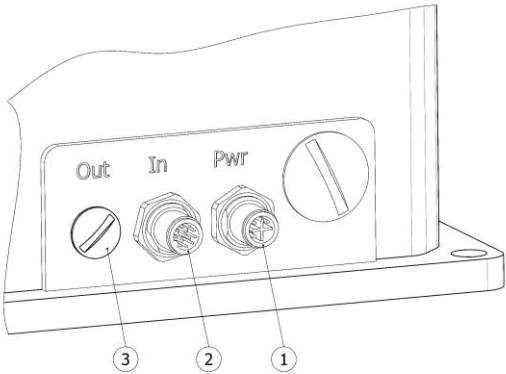

Figure 4: Single drive

- ① Power connector M12-3pin
- ② Signal connector M12-12pin
- ③ Cover

6.4 Technical data

Stroke length	Until 1000 mm
Dimension A (installation dimension)	= stroke + 200 mm
Standard stroke lengths	100; 150; 200; 250; 300; 350; 400; 500; 600; 700; 800; 900 and 1000 mm
Special stroke lengths / installation lengths	Customized possible upon request
Mounting position	any, taking into account the max. moment load
Lifting force	up to 10'000 N push / up to 4000N pull (depending on gear ratio and spindle pitch)
Lifting speed	Up to 29 mm/s (load / spindle dependent)
Protection class	IP 40
Operating voltage	12 VDC ($\pm 20\%$, max. 25 A)** 24 VDC ($\pm 20\%$, max. 24 A)**
Ambient storage temperature	-10 °C to +80 °C
Ambient operating temperature	-5 °C to +60 °C
Self-locking	Yes (standard versions)
Moment load (dynamic)	Mmax. 450Nm
Operating mode / duty cycle	ED 20 % Int.2 min./ 8 min. (at rated load and ambient operating temperature +5°C to +40°C)
Maintenance	maintenance-free
Color	Aluminum anodized / other colors on request
Electrical connection	M12, M12 signal (see chapter 8)
Control options	Manual switch / PLC / CANopen (see chapter 8)

* Availability on request

** Measured current at room temperature and nominal voltage

Completed exams:

IEC 60601-1-2:2014 EN 60601-1-2:2015	Medical electrical equipment - Part 1-2 Medical electrical equipment - Part 1-2
IEC 61000-4-3:2006+A1:2007+A2:2010 EN 61000-4-3:2006+A1:2008+A2:2010	Electromagnetic compatibility (EMC) - Part 4-3 Electromagnetic compatibility (EMC) - Part 4-3
IEC 61000-4-4:2012 EN 61000-4-4: 2012	Electromagnetic compatibility (EMC) - Part 4-4 Electromagnetic compatibility (EMC) - Part 4-4
IEC 61000-4-2:2008 EN 61000-4-2:2009	Electromagnetic compatibility (EMC) - Part 4-2 Electromagnetic compatibility (EMC) - Part 4-2
IEC 61000-4-5:2014+A1:2017 EN 61000-4-5:2014+A1:2017	Electromagnetic compatibility (EMC) - Part 4-5 Electromagnetic compatibility (EMC) - Part 4-5
CISPR 11:2015+A1:2016 EN 55011:2016+A1:2017	Industrial, scientific and medical equipment Industrial, scientific and medical equipment

6.5 Overview image of the lifting column

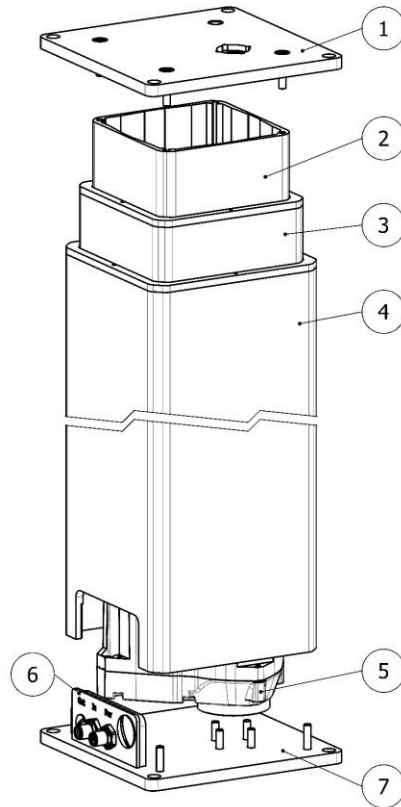
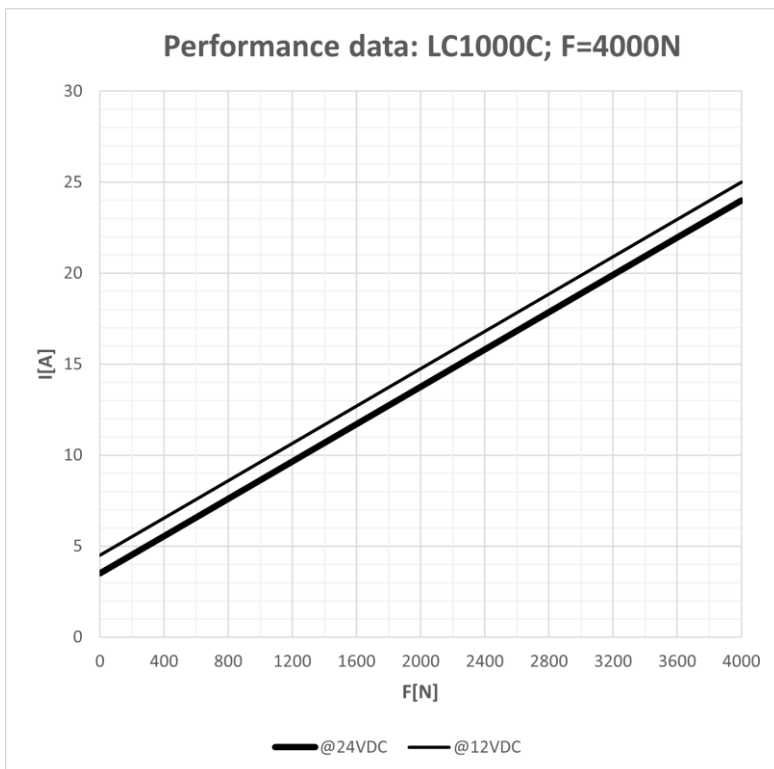
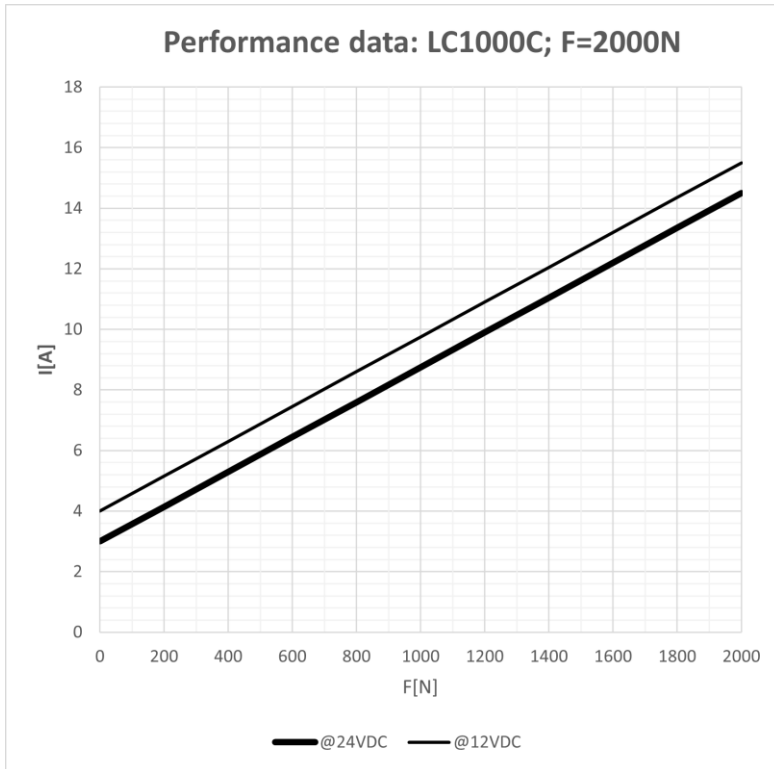

Figure 5

- ① Coupling plate top
- ② Inner profile
- ③ Middle profile
- ④ External profile
- ⑤ Drive unit
- ⑥ Connector panel with connection plugs
- ⑦ Coupling plate bottom

6.6 Performance charts

6.6.1 Current consumption



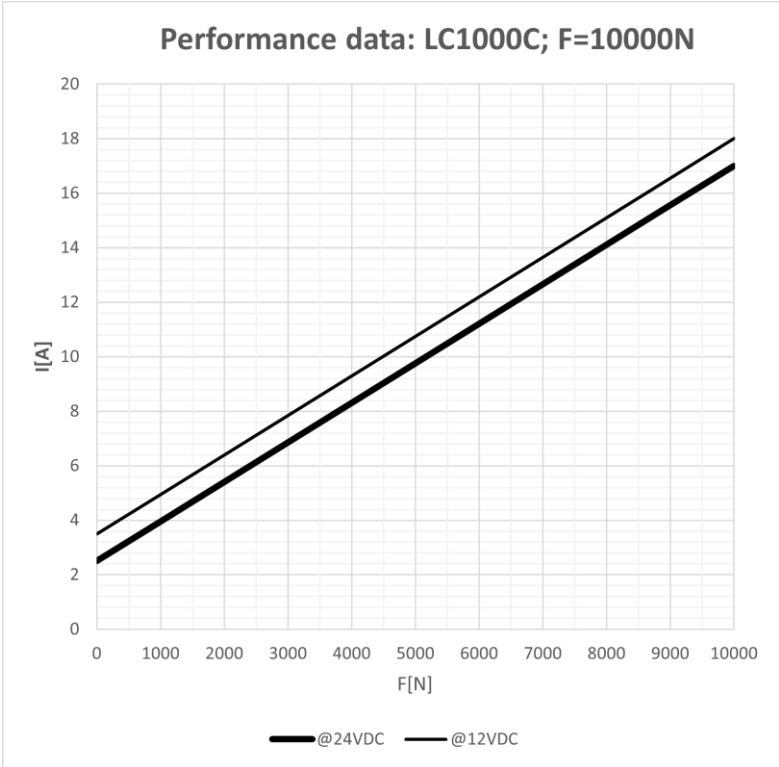

6.6.2 Speeds

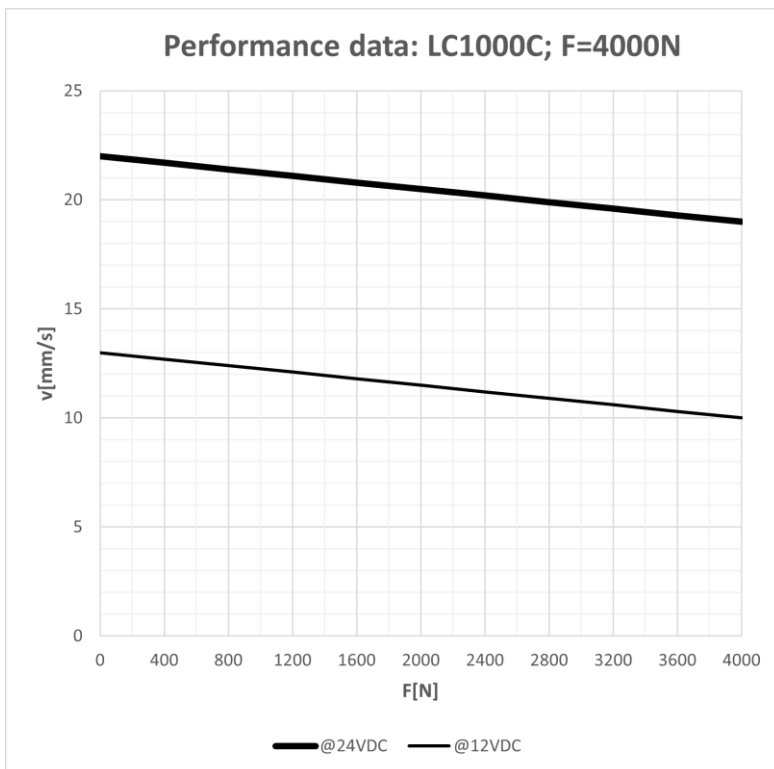
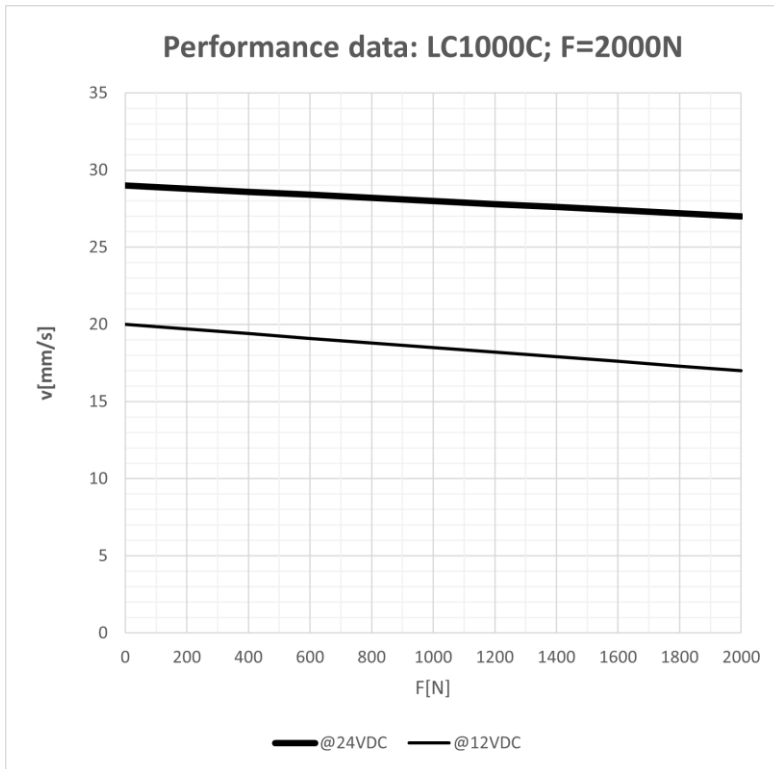

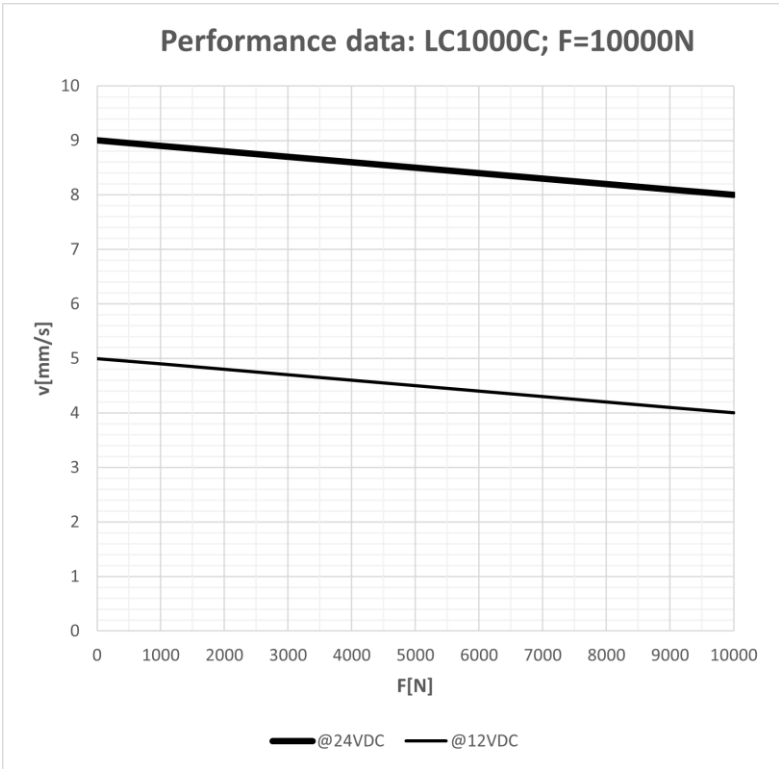

6.6.3 *Weight data*

Stroke [mm]	EBL [mm]	Weight [kg]
100	300	10,8
150	350	12,2
200	400	13,5
250	450	14,9
300	500	16,2
350	550	17,6
400	600	18,9
500	700	21,6
600	880	24,3
700	900	27
800	1000	29,7
900	1100	32,4
1000	1200	35,1

*The stated weights may vary slightly due to different attachments (customer-specific).

6.7 First commissioning

6.7.1 General



Please read the complete document before commissioning the lifting column(s)!

The content of this chapter describes general points for the commissioning of lifting column(s), regardless of their design. It therefore supplements the chapters 6.7.2 and 6.7.3.

- Check the integrity of all components before connecting them. If a lifting column, a cable or other components are found to be damaged, stop commissioning immediately.
- Work on electrical systems must always be carried out in a safe environment and in a de-energized state by a competent person.
- First check the function of the lifting column(s) without load, supervised in a safe environment.
- Verify the retracted and extended end position with the corresponding specification.
- Familiarize yourself with the behavior and control of the lifting column(s) initially without load, supervised in a safe environment.
- When mounting synchronous systems in the structure, make sure that the structure has sufficient compensation areas for the individual lifting columns. You will find more information on this from page 30 onwards.

6.7.2 Single drives



Please read the complete document before commissioning the lifting column(s)!

The definition of the connectors and, if applicable, cables, as well as their functions, can be found in the wiring diagram associated with the lifting column. The connection diagram of the lifting column is printed on the nameplate with the notation "AP.4.xxxxxx" (x=0...9) (for example AP.4.017910). The connection for the standard version is described below.

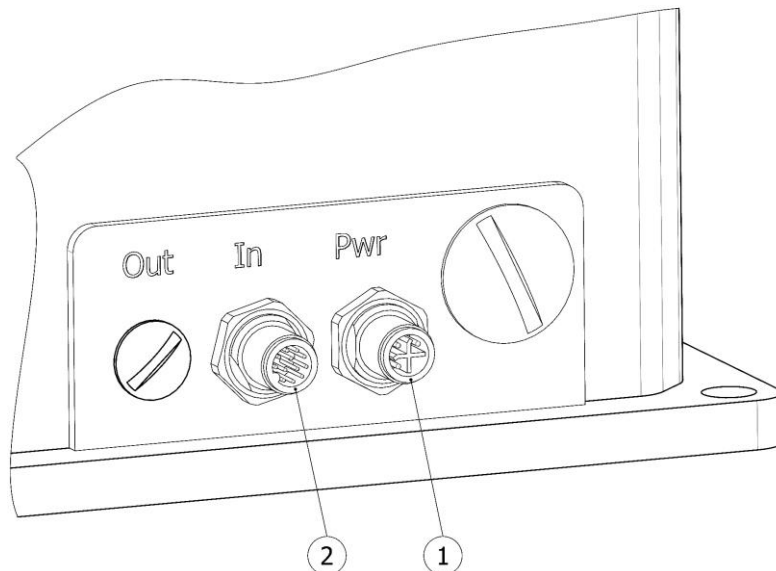

Figure 6



First verify the voltage-free condition of the components to be connected. Connect the communication cable or handset cable ②, which consists of an M12 round connector with 12 pins, to the "IN" connector of the lifting column. Screw the union glands onto the connector hand-tight. If you have a communication cable with an open cable end, connect this to your controller. Make sure that strands that are not connected are insulated.

Connect the power cable ① to the power supply to the "Pwr" plug of the lifting column. Screw the union glands onto the connector hand-tight. According to the connection diagram, connect the power cable to a stabilized voltage source that can supply the lifting column with the specified data.

Make sure that there can be no short circuit between the stranded wires and that they have no contact with conductive surfaces. This could permanently damage the lifting column. The lifting column can be controlled according to the connection diagram.

6.7.3 Synchronous system



Please read the complete document before commissioning the electric drives!

The definition of the connectors and, if applicable, cables, as well as their functions, can be found in the wiring diagram associated with the lifting column. The connection diagram of the lifting column is printed on the type plate with the notation "AP.4.xxxxxY" (x=0...9, Y=M or S) (for example AP.4.**017900M** for a master). The connection for the standard version is described below.

A synchronous system always consists of a master drive and one or more slave drives. The distinction between "master" and "slave" is made via the corresponding marking on the type plates, or visually via the different device connectors:

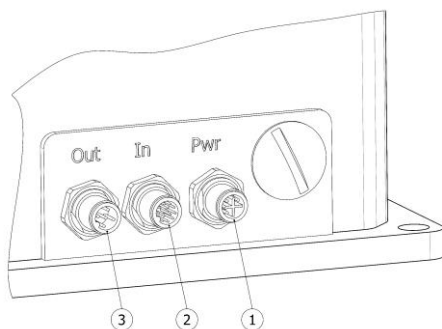

Figure 7: Master

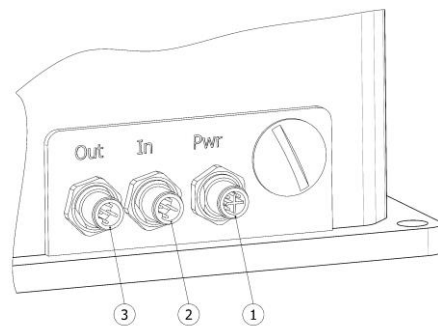









Figure 8: Slave

Art.: LC1000C.xxxxxM	/ Master
ID.No.:	Rj.:(KW/Jahr)
SN:	Bj.:(KW/Jahr)
U Eing.: 24VDC / 16A / Aufn. 385W IP40	
Anschlussplan: AP.4.017900M	
v: 8mm/s	Hub:400mm
Fmax.:Druck 10000N /Zug 10000N	
ED30% Int.3min./7min.	
  	
 PHOENIX MECANO ELEKTROZYLINDER CH-8260 STEIN AM RHEIN	

Art.: LC1000C.xxxxxS	/ Slave
ID.No.:	Rj.:(KW/Jahr)
SN:	Bj.:(KW/Jahr)
U Eing.: 24VDC / 16A / Aufn. 385W IP40	
Anschlussplan: AP.4.017900S	
v: 8mm/s	Hub:400mm
Fmax.:Druck 10000N /Zug 10000N	
ED30% Int.3min./7min.	
  	
 PHOENIX MECANO ELEKTROZYLINDER CH-8260 STEIN AM RHEIN	

First verify the voltage-free condition of the components to be connected. Please connect the lifting columns using the following diagram. First connect the plug of cable ① (3-pin / power supply) to the device installation plug on the drive with the label "Pwr".



Then plug the connector of cable ② (12-pin / open cable end for control, signals, etc.) into the device installation connector labeled "In". If you have also ordered a manual switch, please plug its connector into the device installation plug with the designation "IN".

After that, please insert a connector plug of the communication cable ③ (connector on both sides / connecting cable communication) into the device installation plug with the designation "OUT".

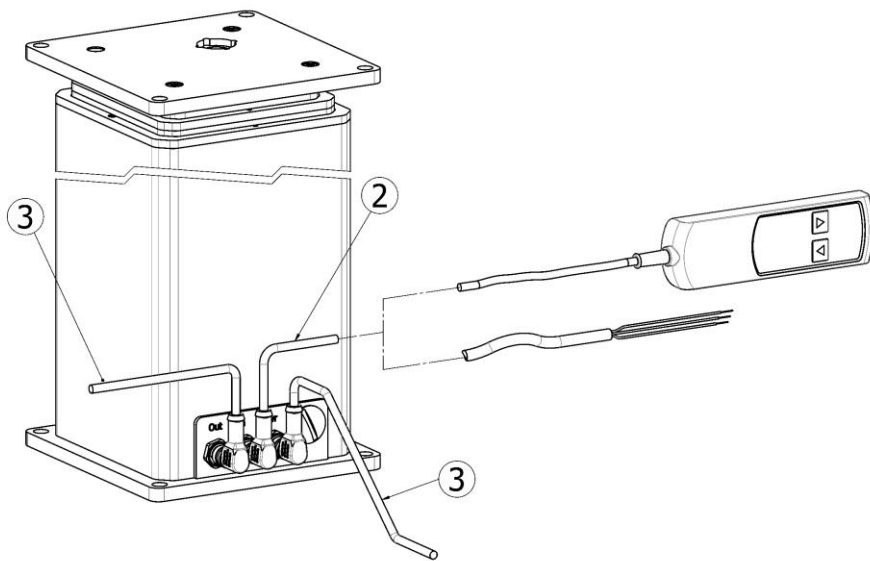

Figure 9

Screw the union fittings onto the plugs hand-tight.

Now connect the communication cable that is plugged into the "OUT" device installation plug of the first drive to the "IN" device installation plug of the next drive. Star-shaped wiring is not permitted!

Proceed according to this scheme until all "slaves" of the synchronous system are connected:

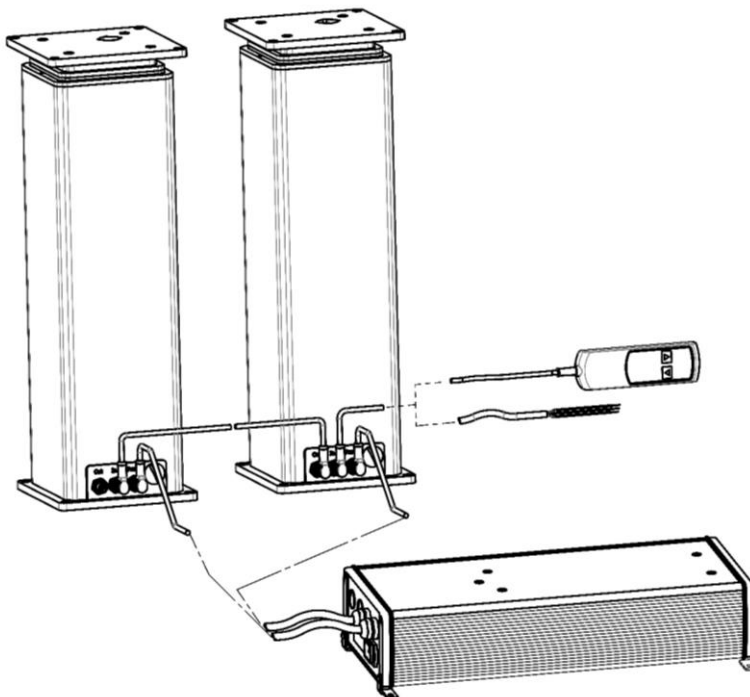

Figure 10

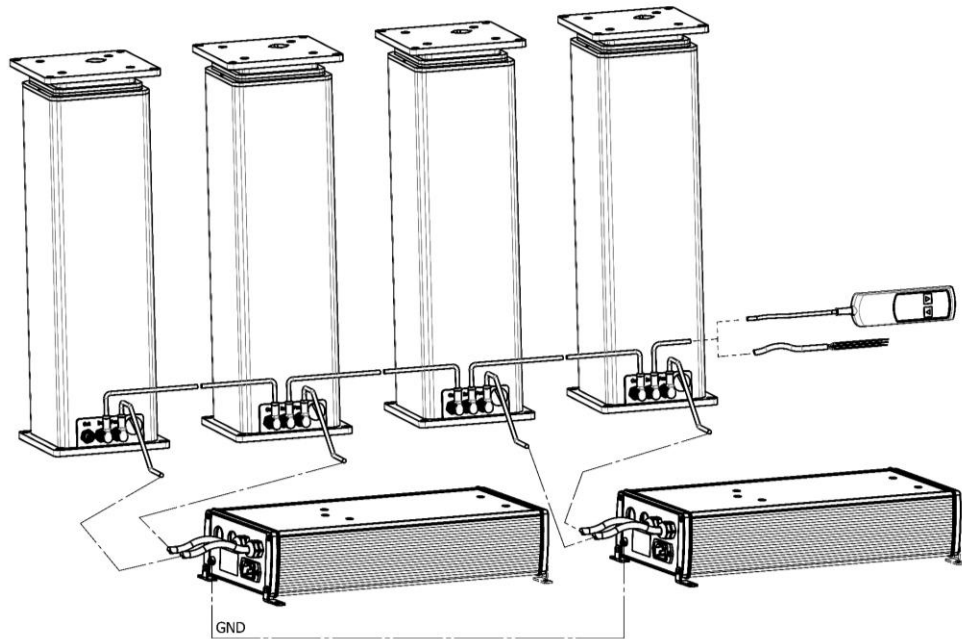

Figure 11

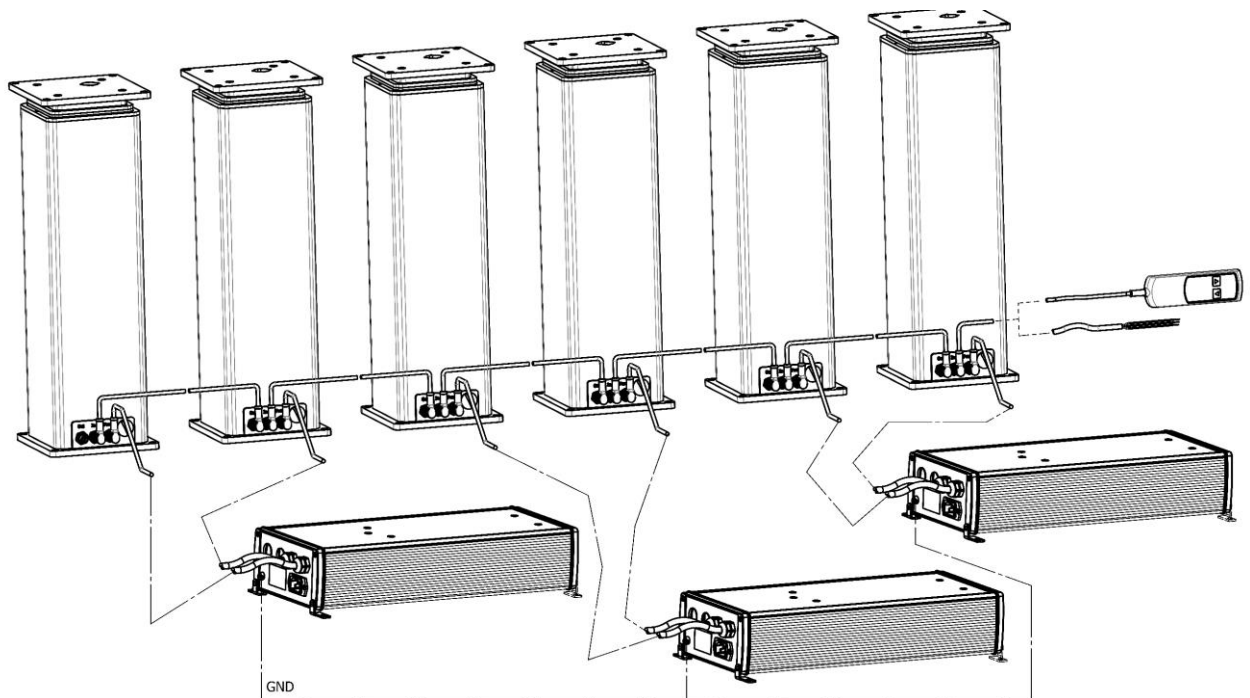

Figure 12

Connect the stranded wires to your controller and the stabilized power supply according to the connection diagram (see chapter 8). Make sure that there can be no short circuit between the stranded wires and that they have no contact with conductive surfaces. This could permanently damage the lifting column.



Before the first operation, the initialization mode (see chapter 6.8.3 on page 26) must be carried out once. The initialization mode causes the slaves to be addressed anew and in dependence on the sequence, the CAN terminating resistor is set automatically in the last slave, and a non-synchronous homing to the retracted end position is performed.

This information is permanently stored within the columns, so that the initialization mode only has to be executed once after a rewiring. If initialization is not possible due to the application, the terminating resistor and the addresses can be configured manually via the CAN bus.

6.7.4 Operation with multiple voltage sources

When using several voltage sources for a synchronous system, or several interconnected individual drives, a common zero potential (minus) must be ensured. As a rule, all minus poles are connected to each other. Always observe the specifications of the manufacturer of the voltage source used. At the power supply PMPS the minus potential is led out to a socket (see following picture). Connect this socket with the socket of other PMPS to ensure a common minus potential. Different potentials can damage the drives!

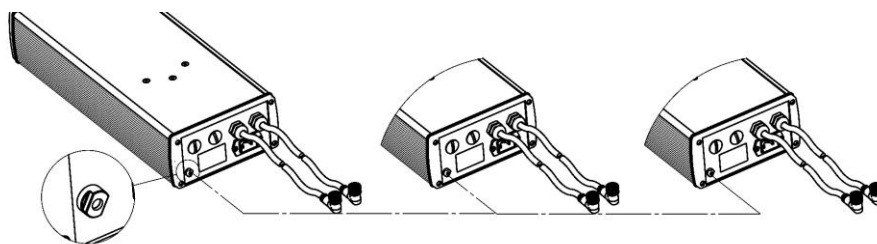

Figure 13

6.8 Operating modes

6.8.1 General

The operating modes described represent standard motion operations that can be executed mechanically or via the digital inputs, usually with a hand switch, without software. The documentation of the communication interface is described in a separate document.

Please note that the available operating modes can be taken from the wiring diagram, and not all operating modes may be available in every drive. For example, the compensation mode for synchronous system will not be available in single drives.

The normal operation (see chapter 6.8.2) is usually mapped by each drive and enables basic operation. It is therefore not explicitly mentioned in the connection diagrams, but is described in the input functions.



Please note that in this chapter 6.8 describes the regular standard. Project-specific or specially adapted connection diagrams may deviate from this in rare cases. The description within the connection diagrams has the higher priority. In case of questions or ambiguities, contact the manufacturer and/or seller of the lifting column for clarification before operation.

6.8.2 Normal operation

The ready-to-operate single drive/synchronous system can be controlled via the inputs (manual switch or customer-specific control). For normal operation, the inputs must always be set individually and not simultaneously. By default, inputs 1 and 2 are assigned to move to the respective maximum position. The drive stops automatically when the end or configured target position is reached. The drive can be stopped at any position by releasing the handset key, or by interrupting the corresponding input signal. A slight latency between setting and start of travel, or removal and stop is normal. Note that usually when a stop is made, the speed is reduced via a ramp, and thus does not stop abruptly within the limits. With a synchronous system, position compensation travels of individual slaves can also take place before and after the travel, provided there is a position difference.

Synchronous system - prerequisite for travel: In synchronous systems, the **number of slaves** is stored in the master. In addition to the number, each station contains an adjustable **tracking error value** that defines the maximum permissible deviation from the master position. If the master detects that the number of active slaves does not match the stored number, the addresses are not correct, or at least one station reports a tracking error, the master refuses to move or stops the system. Normal operation is no longer possible in this constellation for safety reasons. As a rule, the other operating modes (see this chapter) can provide a remedy.

Synchronous system - configuration: Make sure that all participants contain identical parameters.

The pin assignment and the interface specifications can be found in the corresponding connection diagram (see nameplate and chapter 8 from page 34).

Caution: Verify the direction of travel and positions before each installation in a safe environment.

Caution: Do not exceed the specified duty cycle. This may result in damage to the lifting column.

6.8.3 Initialization mode

The following figure shows the activation pattern for the initialization mode. For activation, input 1 and 2 must be actuated simultaneously nine times within 6s. All actuations that have an actuation deviation of less than 100ms are considered simultaneous. After the activation of the mode, the initialization can be executed by a further simultaneous and continuous activation of the inputs 1 and 2. In this mode, all drives are newly addressed, homing is performed (by default, unless explicitly described otherwise, all drives homing to the internal limit switch) and then the current position of the limit switch is set for all drives. Within the mode, it is possible to stop and restart as often as required. If the time period exceeds 2s without a common activation of the inputs 1 and 2, the mode will be left automatically.

For actuators of the LC1000C series from Phoenix Mecano Solutions AG, it is not necessary to manually set a BUS terminating resistor at the last system participant (slave) - this is done fully automatically. The last slave and master have automatically set the terminating resistor for the CAN bus.



Make sure that no synchronous operation is performed during the initialization run. Each drive runs independently. During initialization, the terminating resistor of the slave may be deactivated.

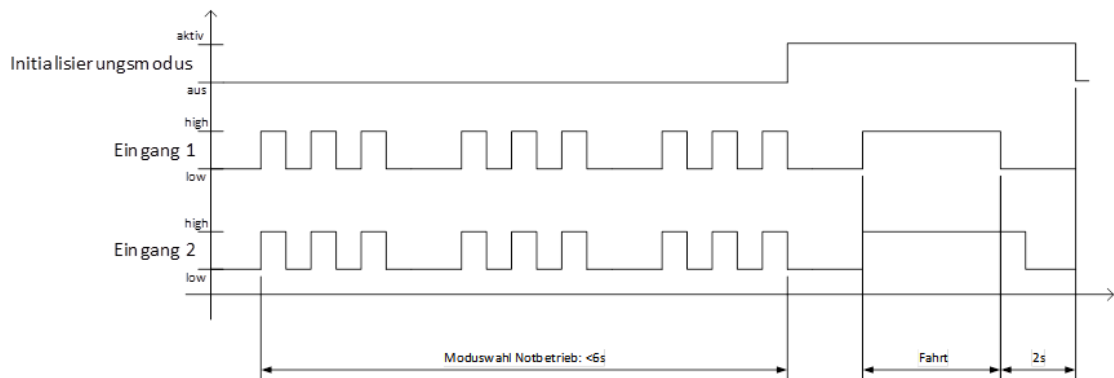

6.8.4 Compensation mode

In case of exceeding the following error (maximum permissible position deviation between master and the slave drives in a synchronous system), normal operation is blocked. The compensation mode moves the slaves to the position of the master to enable normal operation again. These are non-synchronized single drives of the slaves with a relevant position deviation to the master. A safety risk assessment must be carried out before a compensation travel (no obstacles or danger of personal injury).

Attention: Exceeding the tracking error is an indicator of non-uniform load distribution, missing balancing elements, blockages, poor supply voltage connection, etc. pp.

Equalization mode: Simultaneous actuation within 100ms of input 1 and 2 for more than 20s. After 20s, the compensation mode starts. An interruption of the actuation of one or both inputs stops the travel immediately. For a restart, the activation must be performed again.

6.8.5 Emergency operation mode

Under certain circumstances, it may be possible that individual drives in the synchronous system are no longer responsive and can therefore no longer be moved. Possible causes for this could be:

- Power supply is no longer available (cable break, power supply defect, battery defect, etc. pp.)
- The synchronous system is in tracking error due to a collision in the overall application and at least one slave cannot perform the necessary compensating movement due to the collision.
- The internal control electronics installed in the drive are damaged.
- External influences.
- Defect of a drive in a synchronous system.
- List not exhaustive, as many error causes can occur.

In order to move the system out of sync and/or incompletely, for example to be able to remove a defective drive from an existing application, emergency operation can be executed. An active operating voltage and an intact communication line are required to perform emergency operation.



In case of a defect of the master drive (defect of the integrated control electronics) this emergency operation mode is not available - in this case contact the manufacturer!

The parameter described in chap. 6.8.4 mentioned "Compensation mode" requires that all slave drives communicate with the master and have no permanent / recurring errors. The "Emergency mode" ignores missing / defective slave drives. The "Emergency mode" is used to move the still functional participants of the system one last time in order to then be able to replace a defective drive. Please note that the defective stations no longer move and must therefore be mechanically decoupled beforehand!



Extreme caution is imperative here, as ALL safety functions are deactivated!

The user is responsible for securing suspended loads or attachments so that neither personal injury nor damage to property can occur during manual emergency adjustment!

Emergency operation to drive an incomplete system without synchronization:

The following figure shows the activation pattern for emergency operation. For activation, input 1 and 2 must be actuated simultaneously three times, then input 1 three times and then input 2 three times within 6s. After that, a synchronous system can be moved in or out to a safe position. All actuations with an actuation deviation of less than 100ms are considered simultaneous.

If the time period exceeds 2s without an activation of the inputs 1 or 2, the mode will be left automatically.

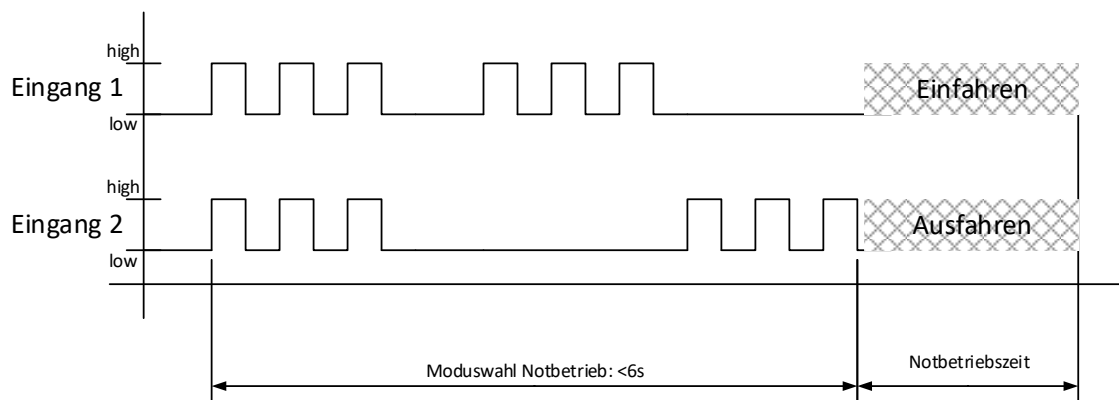

6.9 Fine adjustment of the installation dimension

The retracted length (installation dimension) can be subsequently corrected by max. + 3 mm. For this purpose, the black protective cover (1) on the upper mounting plate must be removed. An Allen key size 10 is used for adjustment. - Turning counterclockwise (+) = lengthen installation dimension - Turning clockwise (-) = correction of installation dimension



Attention: An adjustment of more than +3mm would result in destruction of the drive.

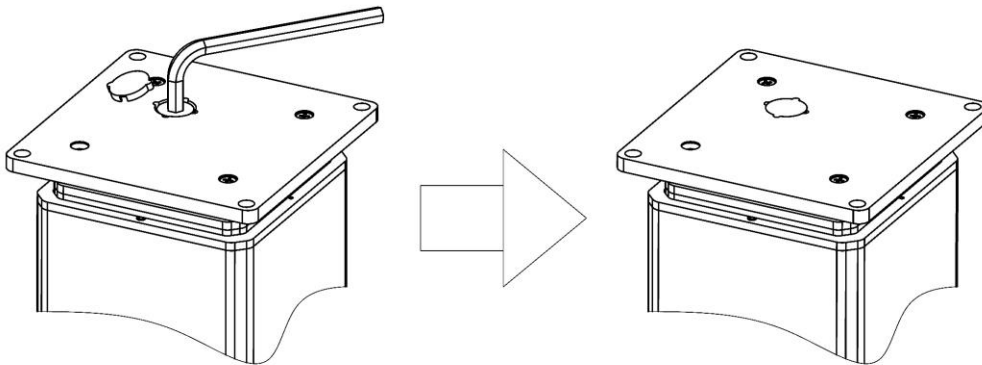

Figure 14

7 Phases of life

7.1 Scope of delivery of the lifting column

The lifting column is supplied ready for operation as a single component. Power supply and manual switch or accessories are not included in the scope of delivery, unless they have been explicitly ordered.

7.2 Transport and storage

The product must be inspected by suitable personnel for visible and functional damage. Damage caused by transport and storage must be reported immediately to the person responsible and to Phoenix Mecano Solutions AG.

Commissioning of a damaged lifting column is prohibited.

Ambient conditions prescribed for the storage of the lifting column:

- No oily air
- Contact with solvent-based coatings must be avoided
- Lowest / highest ambient temperature see table in chapter 6.4
- Air pressure: from 700 hPa to 1060 hPa

Deviating environmental influences must be approved by Phoenix Mecano Solutions AG.

7.3 Important notes on mounting and commissioning



It is essential that you observe and comply with the following instructions. Otherwise, persons may be injured or the lifting the lifting column or other components may be damaged.

- This lifting column must not be provided with additional holes.
- This lifting column must not be used outdoors.
- The lifting column must be protected against the ingress of moisture.
- This lifting column may only be used in environments that correspond to the IP protection class specified on the nameplate.
- When mounting, it must be taken into account that the stand and support surface rest completely on a metal surface at least 5mm thick.
- After installation and commissioning, it is essential that the power supply plug is freely accessible.
- The lifting column must not be driven on "block". There is a risk of mechanical damage.
- The lifting column must not be opened.
- The user must ensure that no hazard arises when the power supply is active.
- When designing applications with this lifting column, care must be taken to avoid crushing and shearing points. These must be secured and marked accordingly.
- A self-start of the lifting column due to a defect must be stopped immediately by switching off the power supply.
- If the supply line is damaged, the lifting column must be taken out of service immediately.
- The lifting column is not designed for continuous operation. The switching frequency per hour specified for your application must not be exceeded.
- It is mandatory that an EMERGENCY STOP circuit is implemented on site, which reliably interrupts the operating voltage in the event of a failure or malfunction of the incomplete machine!
- A self-start of the lifting column(s) due to a defect must be stopped immediately by switching off the power supply (EMERGENCY STOP see above).

7.3.1 Synchronous operation of electric cylinders and lifting columns

In the following chapters (up to and including chapter 7.4.7) you will see graphical representations of the lifting columns. The specifications and notes apply equally to electric cylinders and lifting columns - with the difference that low lateral loads are permissible for lifting columns, but **completely prohibited for** electric cylinders, i.e. additional guide elements are necessary! For better comprehensibility, electric cylinders and lifting columns are referred to collectively as "adjustment units" in these chapters.

In the ideal case, two or more adjustment units stand parallel to each other and move up and down synchronously.

In reality, there are many factors that do not allow this simple approach. Manufacturing tolerances are unavoidable in the production of the adjustment units, as well as your own attachment parts. In the worst case, the tolerances of different parts can add up and lead to distortions and damage.

7.3.2 Different heights

A rigid connection forces the adjustment units to a common height. If the load / the connecting plate is screwed tight, the adjustment units become tense. As a result, the running properties can deteriorate and the service life is reduced. The cause of different heights is in most cases an uneven floor. Therefore, the base plate of the adjustment units should be adjustable in height. However, it is also possible that due to manufacturing tolerances the adjustment units have different heights when they are moved together.

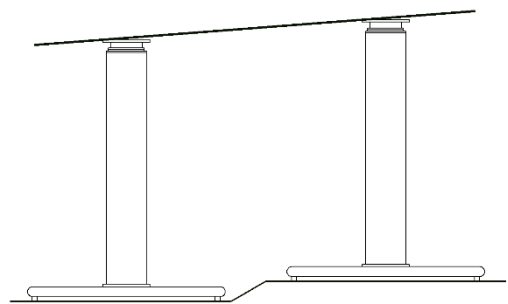

7.3.3 Parallel alignment

If the adjustment units are not parallel to each other, the distance between the upper attachment points changes during travel. A rigid connection, however, keeps this distance constant. As a result, considerable forces act on the adjustment units, which can be damaged. In this case, too, the adjustment units should be precisely aligned. Uneven floors can be aligned with the aid of an adjustable base plate.

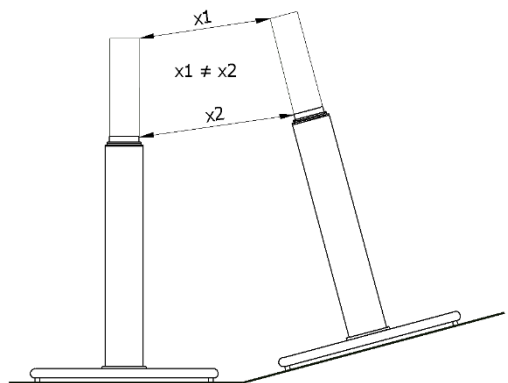

7.3.4 Crooked connecting plates

If the weight/connecting plate does not lie flat on the adjustment units, the Synchro system will become tense when it is screwed together. This results in undesirable transverse forces that stress the guides of the adjustment units. Please ensure that the components are processed correctly.



Use the RK SyncFlex compensation plate to compensate for height differences between two or more adjustment units, or ensure that the height difference is compensated for before initial startup by attaching appropriate compensation elements. For information on the application and technical data of this article, please refer to the current product catalog.

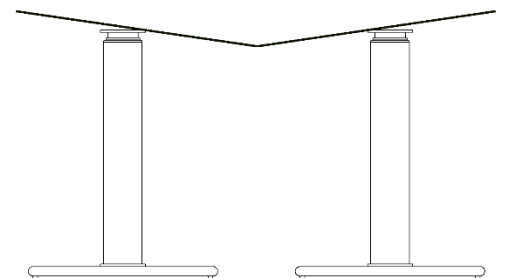

7.3.5 The ideal structure

In a synchronous system, the positions are to be controlled during travel so that all adjustment units have exactly the same height at all times. In practice, this is not possible because a controller must first detect a control deviation before it can eliminate it. For the Synchro system, this means that a deviation from an ideal synchronous travel must always be allowed.

Special requirements are therefore placed on the connections between the load / connecting plate and adjustment units. Ideally, the design allows a certain range of movement.

The adjustment units usually stand on heavy base plates. These guarantee the stability of the construction. The connections between the base plate and the adjustment units do not allow linear and rotary movements. Therefore, even if the base plates are not connected to each other, it can be called a rigid connection. The mobility must therefore be created at the upper connection to the load / connecting plate.

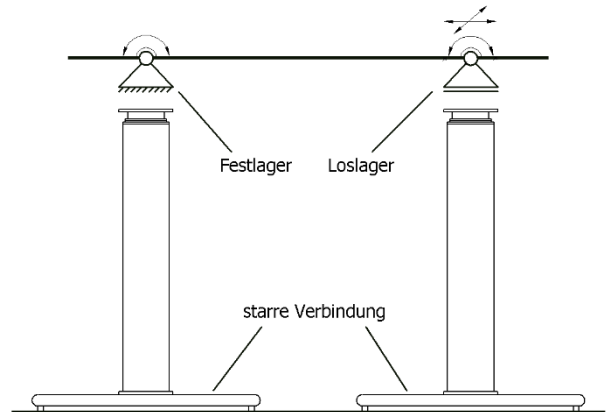

Due to the control deviation, slight height differences must be able to be compensated by the design. Therefore, it is useful if the connection between the adjustment units and the load / connection plate is mounted so that it can rotate a little or if the load / connection plate has the required flexibility.

Avoid countersunk screws for fastening the load / connecting plate. These center themselves in the drill holes when screwed tight. If the hole pattern of the load / connecting plate does not match that of the adjustment units exactly, this will lead to distortion or even destroy the screw channels. It is better if the drill holes are slightly larger than the fastening screws used. In this way, inaccuracies in the hole pattern can be compensated.

If the adjustment units are not exactly parallel, the upper distance between them may change. For this reason, only one adjustment unit may be fixed (fixed bearing) and all others should have a floating bearing of the load / connection level (floating bearing). This ensures that no distortions can occur during travel.

The greater the distance between the adjustment units, the better the driving behavior. If the adjustment units are close together, control deviations have a greater effect. The load / connecting plate has an unsteady effect during travel. If the distance increases, the effect decreases.

7.3.6 Load distribution

A small example: You build a table with four adjustment units. Each adjustment unit can carry 1000N. So the adjustment units together may carry a load of $F_{max} = 4000 \text{ N}$ (incl. table top, etc.), provided that the load is symmetrically located in the center of the table. If you move the load to a corner of the table, then the lifting column under this corner must carry almost the entire 4000N. This would inevitably lead to overloading. When planning your application, please pay attention not only to the total load, but also to the load of the individual adjustment units.

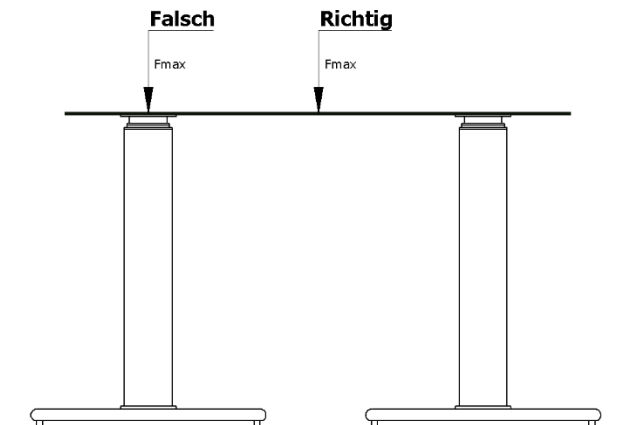

7.4 Mounting

After receiving the lifting column, check the device for any damage. The lifting column is delivered ready for operation without the control unit.

The mounting holes for installing the lifting column are located in the mounting plates of the lifting column. The fastening screws are not included in the scope of delivery.

- 4 mounting holes for M10 threaded screws in the mounting plate-pushrod side.
- 4 mounting holes for M10 threaded screws in the mounting plate-motor side.
- Perform a test or trial run.



Failure to observe this procedure will result in damage to the lifting column! The warranty will be voided!

With regard to the installation position of the components, care must be taken to avoid crushing and shearing points, especially taking into account the subsequent application.

7.5 Maintenance

The lifting column is basically maintenance-free; however, it is not wear-free.

Possible wear can be recognized by faulty function, increase in the play of the moving parts or unusual noises emanating from the lifting column.

Worn product parts are replaced by the manufacturer. The lifting column must be sent in for this work. If worn product parts are not replaced, the safety of the product may no longer be guaranteed.

All work with the lifting column may only be carried out in accordance with these instructions. The device may only be opened by authorized and trained personnel.

If the drive is defective, we recommend contacting the manufacturer or sending in this lifting column for repair.

- When working on the electrics or on the electrical elements, they must be de-energized beforehand to prevent the risk of injury.
- Unauthorized conversions or modifications to the lifting column are not permitted for safety reasons.
- Safety-relevant equipment must be checked regularly for completeness and function, i.e. at least once a year depending on the frequency of use.

7.6 Cleaning

You can clean the handset and profile outer surfaces of the lifting column with a lint-free, clean cloth.



Solvent-based cleaners attack the material and can damage it. Attention: Handset does not have protection class IP69K, but IP40 and must therefore not be washed with a high-pressure cleaner or exposed to moisture - damage would be the immediate consequence!

7.7 Disposal and take-back

The lifting column must either be disposed of in accordance with the applicable guidelines and regulations or returned to the manufacturer.

The manufacturer reserves the right to charge a fee for the disposal of these drives.

The lifting column contains electronic components, cables, metals, plastics, etc. and must be disposed of in accordance with the applicable environmental regulations of the respective country.

In Europe, disposal of the product is subject to EU Directive 2002/95/EC or the respective national legislation.

8 Appendix: Connection diagrams

The following are the existing connection diagrams attached to this document.

Connection AP.4.017900M (M=Master)

Pin assignment

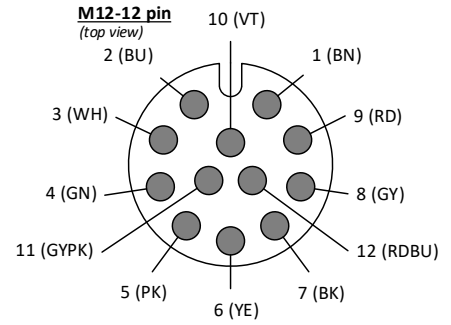
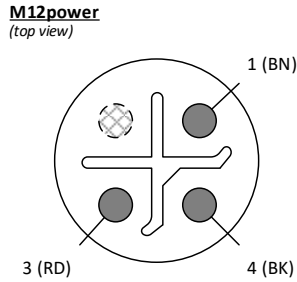
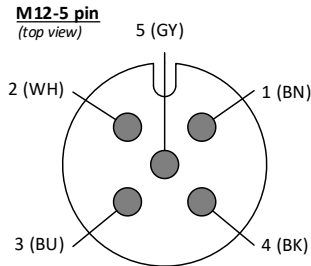

Pin assignment M12power (3-pin)

*** Supply voltage ***

Pwr

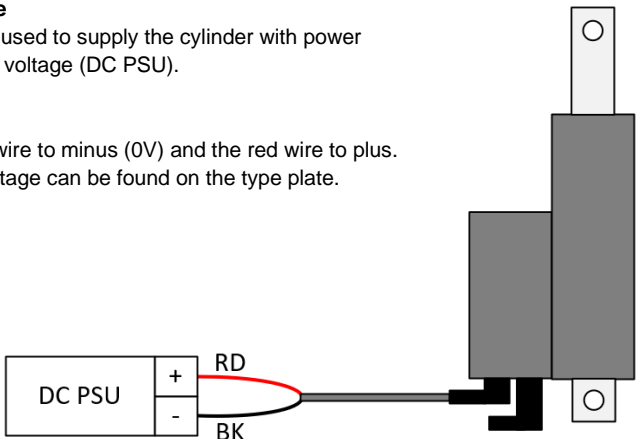
Pin	Description	
Pin 1 Brown (BN)	Do not connect	<p>V C supply voltage The power cable is used to supply the cylinder with power from the DC supply voltage (DC PSU).</p> <p>Connection Connect the black wire to minus (0V) and the red wire to plus. The permissible voltage can be found on the type plate.</p> 
Pin 3 Red (RD)	DC power supply	
Pin 4 Black (BK)		

Pin assignment M12 Signal (12-pin)

*** Communication & control plug ***

In

Pin	Description	
Pin 1 Brown (BN)	Voltage output	Fused supply voltage for switching the digital inputs on this plug. Any other use is not permitted.
Pin 2 Blue (BU)	Signal GND	CAN communication interface Interface for control, query, update, and parameterization of the linear drive. Signal GND is capacitively and ohmically coupled with the GND of the cylinder to avoid critical cross currents. Note: Ensure an identical GND potential for all CAN BUS nodes.
Pin 3 White (WH)	CAN high	
Pin 4 Green (GN)	CAN low	
Pin 5 Pink (PK)	Output 4	Digital outputs The linear drive indicates when the retracted and extended end positions have been reached with a separate pin each. The output is designed for switching small loads such as relays, magnetic valves, or signal lamps. The internal resistor R is connected to the linear drive supply voltage V _{DD} (e.g. 24V) and allows for example the direct operation of common signal LEDs without separate series resistor. Specification <ul style="list-style-type: none"> • R = 2.4k Ω • V_{DS} = 0...30 V_{DC} • I_{DS} = 0...300m A Definition <ul style="list-style-type: none"> • Output 3 Retracted • Output 4 Extended
Pin 6 Yellow (YE)	Output 3	

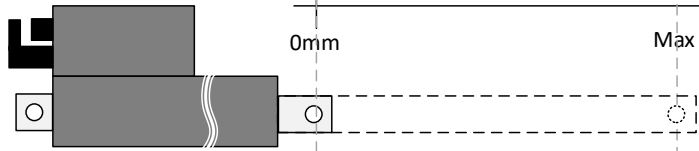
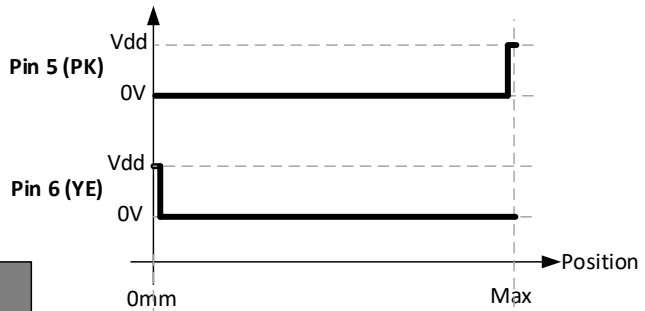
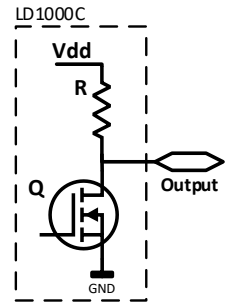
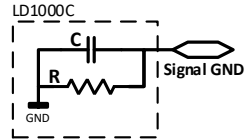

Continued on next page

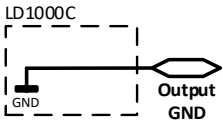
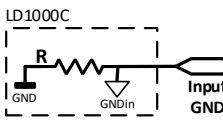
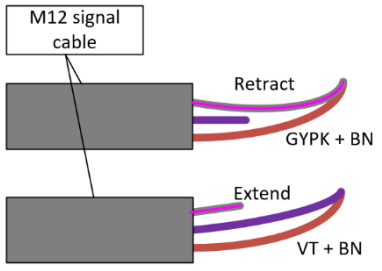
<i>Continued from previous page</i>		
<p>Pin 7 Black (BK)</p>	<p>Output GND Common zero potential of the outputs (see pin 5 and 6).</p> <p>Do not connect the wire to the minus of the linear drive supply voltage (see M12power, pin 4). The linear drive could be damaged by the cross currents that can occur.</p> <p>This line is necessary only if the control unit has a galvanically isolated supply to the linear drive.</p>	
<p>Pin 8 Grey (GY)</p>	<p>Input GND Common zero potential of the inputs.</p> <p>Connecting this wire is recommended at input voltage levels below 5V. Therefore, the voltage drop on the negative wire (M12power, pin 4) has an nearly insignificant impact on the input signal.</p> <p>Connection of this wire to a control unit galvanically isolated from the LD1000 supply voltage (M12power) is required.</p>	
<p>Pin 9 Red (RD)</p>	<p>Input 3</p>	<p>Digital Inputs The digital inputs allow you to extend and retract the actuator, as well as to select other operating modes (see assembly instructions).</p> <p>The linear drive allows passive and active control. For passive control, connect the brown wire (pin 1) to the corresponding input (see diagram opposite). This can be done, for example, via a manual switch (accessory), pushbutton or relay contacts.</p> 
<p>Pin 10 Violet (VT)</p>	<p>Input 2</p>	<p>In the case of active control, connect the inputs to the cylinder linear drive der voltage, for example. The low "high" level also allows control with a 3.3V controller.</p> <p><u>Configuration</u></p> <ul style="list-style-type: none"> • [Input 1] Retract • [Input 2] Extend • [Input 3] No function defined
<p>Pin 11 Gray-Pink (GYPK)</p>	<p>Input 1</p>	<p><u>Other operating modes (see assembly instructions)</u></p> <ul style="list-style-type: none"> • Initialization mode • Adjusting mode • Emergency operation mode <p><u>Specification</u></p> <ul style="list-style-type: none"> • U = 0 ... 30Vdc* • Level definition <ul style="list-style-type: none"> ○ [high] ≥ 3V* ○ [low] < 0.8V* • Typical current consumption per input: 5mA <p>*Reference to "Input GND"</p>
<i>Continued on next page</i>		

Continued from previous page

Pin 12
Red-Blue (RDBU)

Output analog (Position of the actor)
The LD1000C generates a linear output voltage depending on the current position.

Specification

- Load $R_L \geq 1k \Omega$

Output level for 12V cylinder

- **[0.5V*]** Retracted position
- **[4.5V*]** Extended position

Output level for 24V cylinder

- **[2V*]** Retracted position
- **[10V*]** Extended position

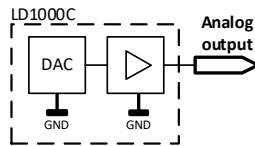
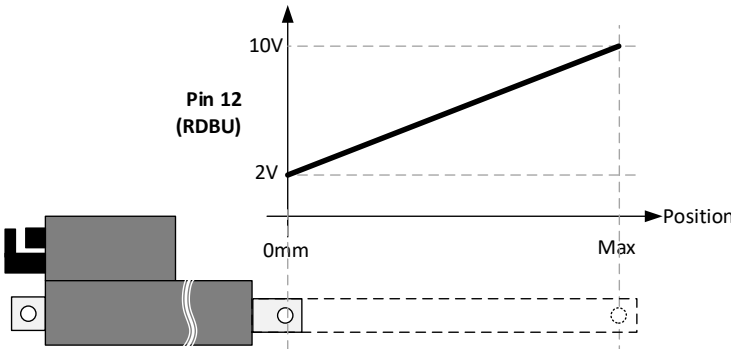
*Reference to "Output GND"

Pin assignment M12 Signal (5-pin) - OUT

*** Communication plug (internal) – Slave ***

OUT

Pin	Description	
Pin 1 Brown (BN)	CAN low	CAN communication interface Interface for control, query, update and parameterization of the cylinder.
Pin 2 White (WH)	CAN high	
Pin 3 Blue (BU)	Do not connect Internal signals.	
Pin 4 Black (BK)		
Pin 5 Grey (GY)	Output GND Common zero potential of the outputs. You can connect this wire with the "input GND" of the next slave	

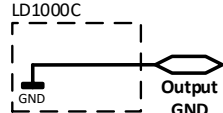

Note: All five pins of this connector are to be connected direct and complete with all five pins to the connector IN of the next slave.

Example

Connection example – drive – passive

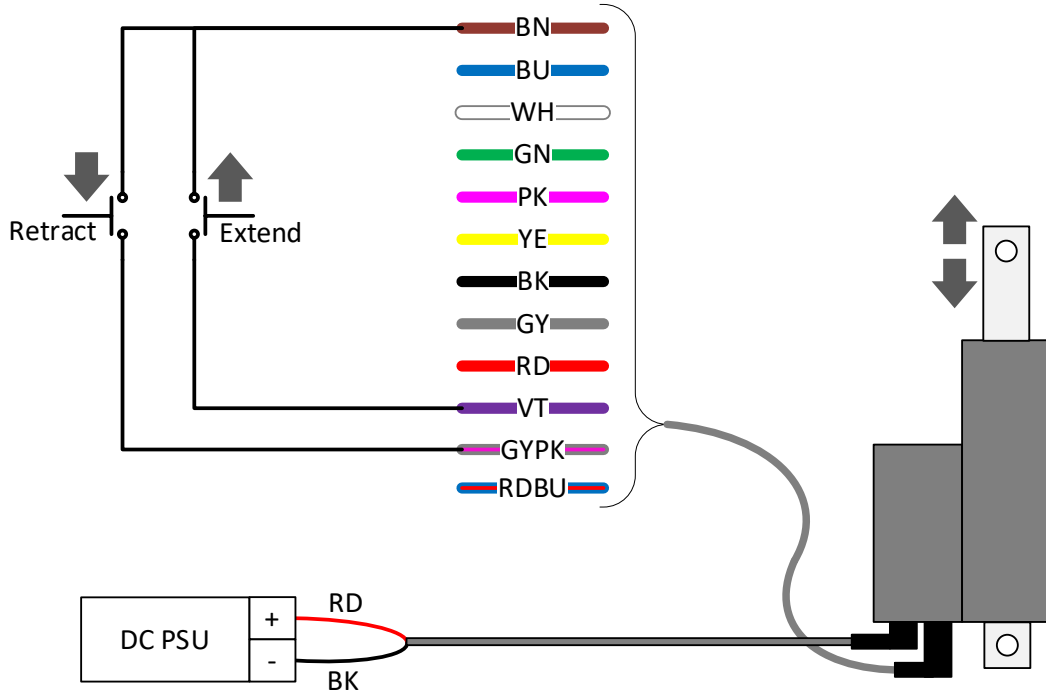

Connection example – drive – active

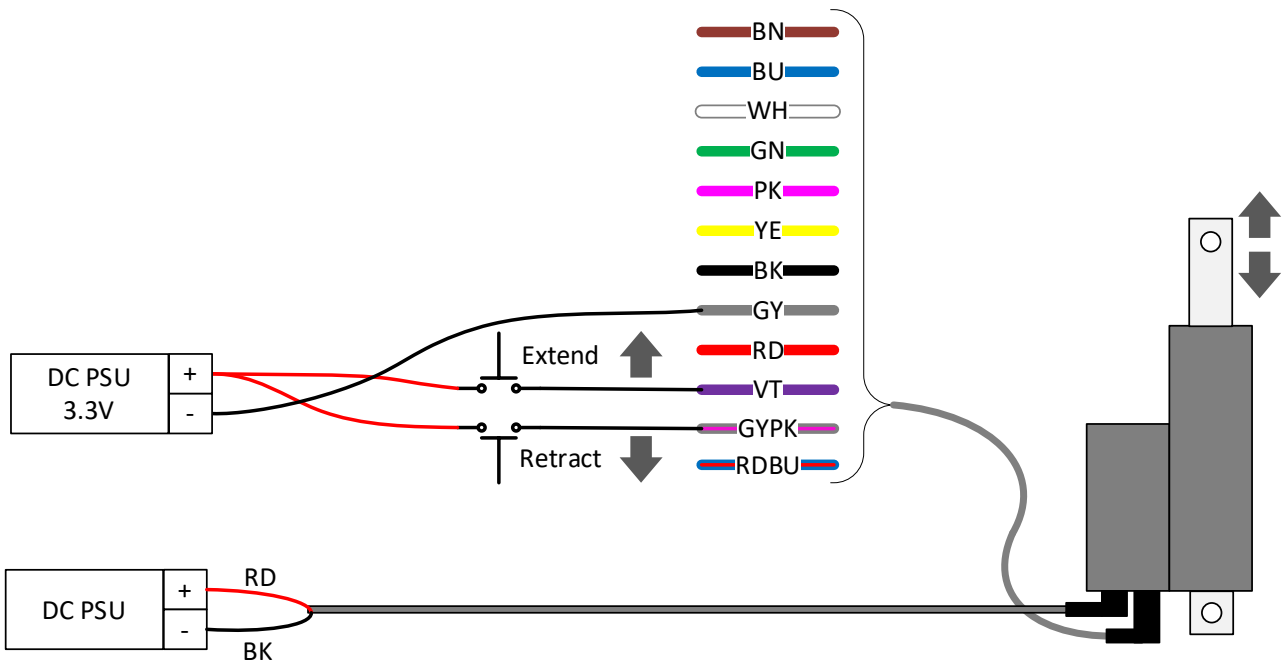

Connection example – Feedback signal

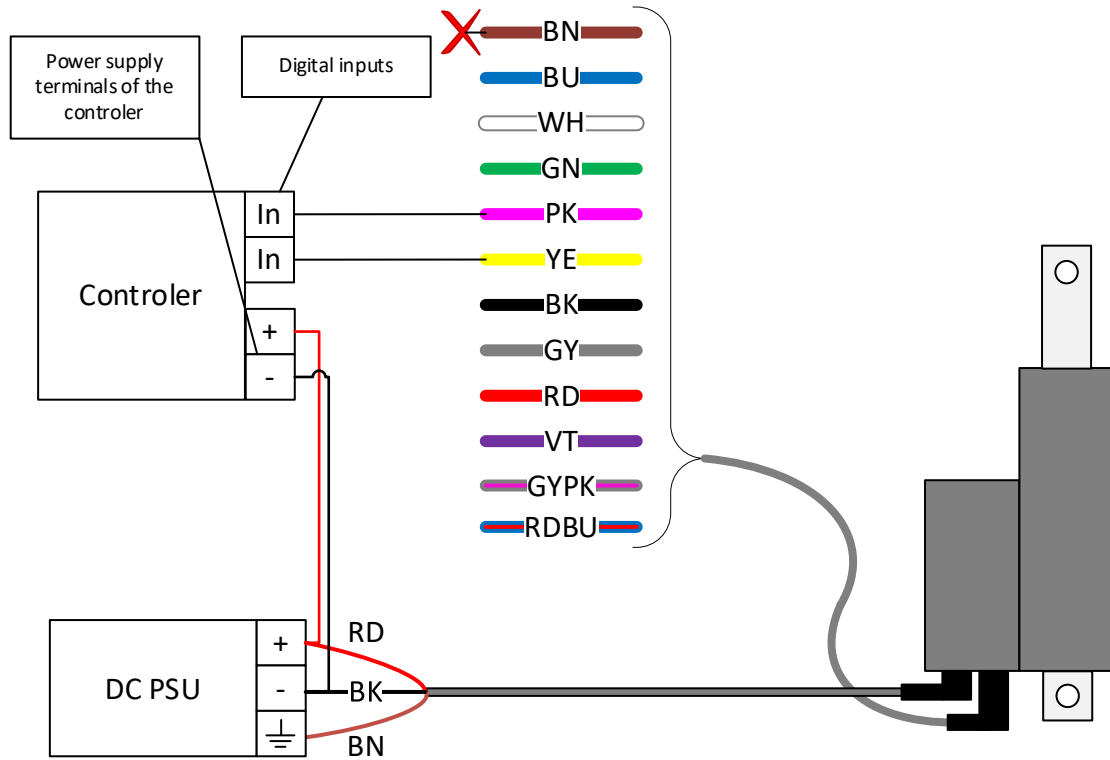

Note: The figure shows a usual application in which the control unit is connected to a central GND (minus), as is also the cylinder. The brown wire (GND) of the 12-pole cable is not allowed to be connected in this constellation.

Connection example – CAN

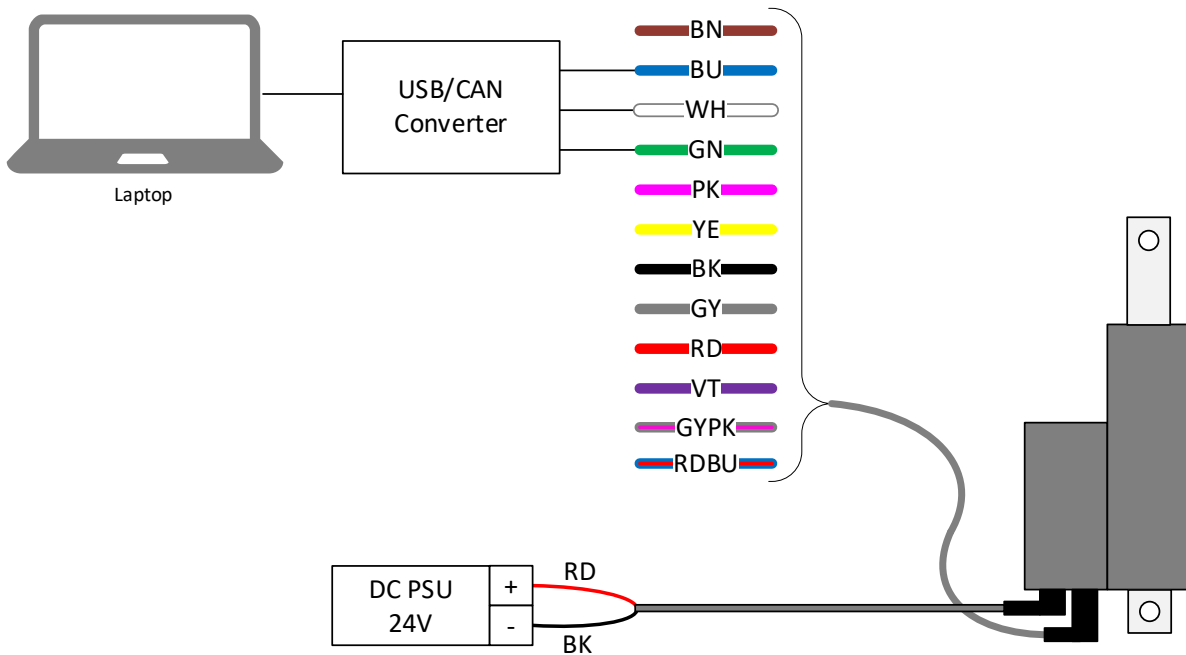

Connection example – Switch a relay

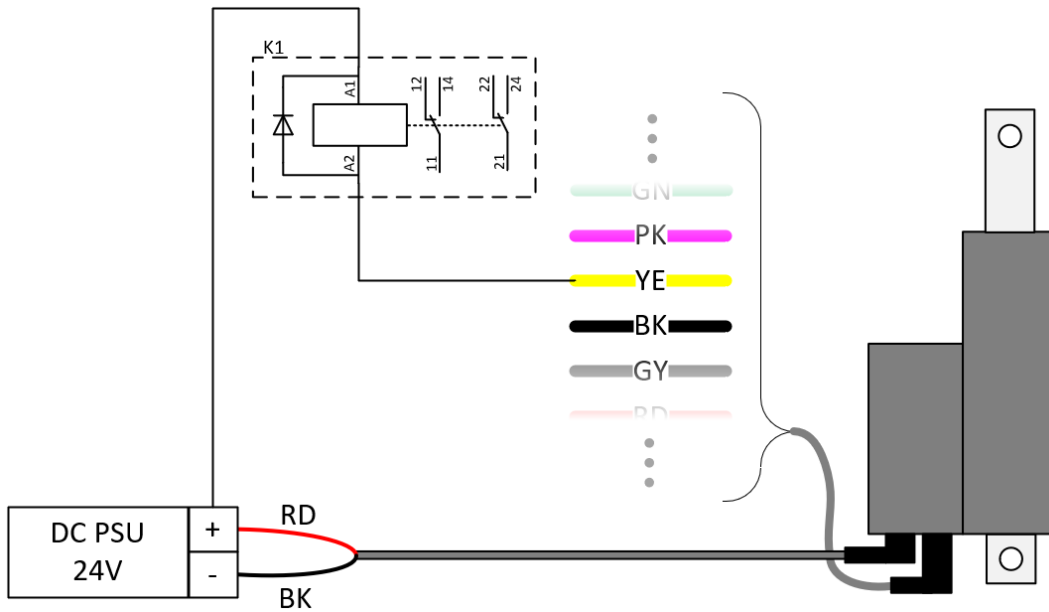

K1: Relay with integrated free-wheeling diode (Wago, 788-312)

Note: For a better overview, only one relay is shown at output 3.

Connection example – Relay with two galvanic isolated power supply units

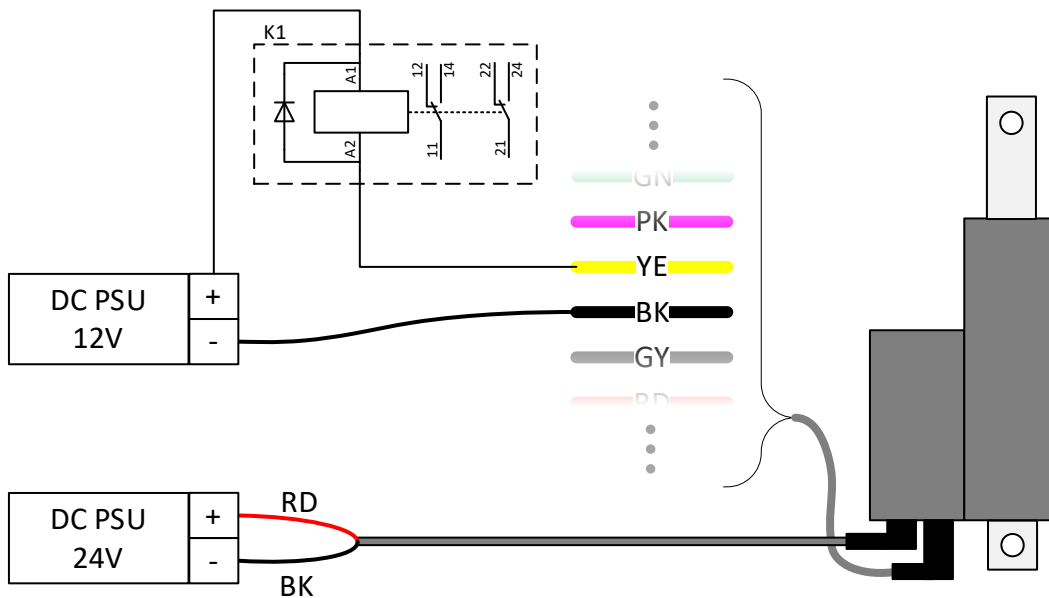

K1: Relay with integrated free-wheeling diode (Wago, 788-312)

Note: For a better overview, only one relay is shown at output 3.

Output Ground (GND) Concepts

GND concept with two separate power supplies

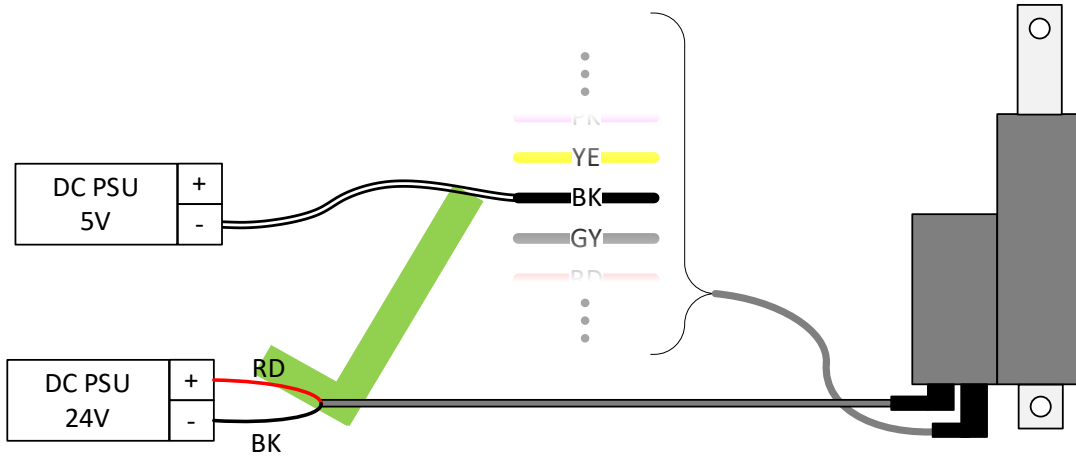

GND concept with two power supplies and common GND

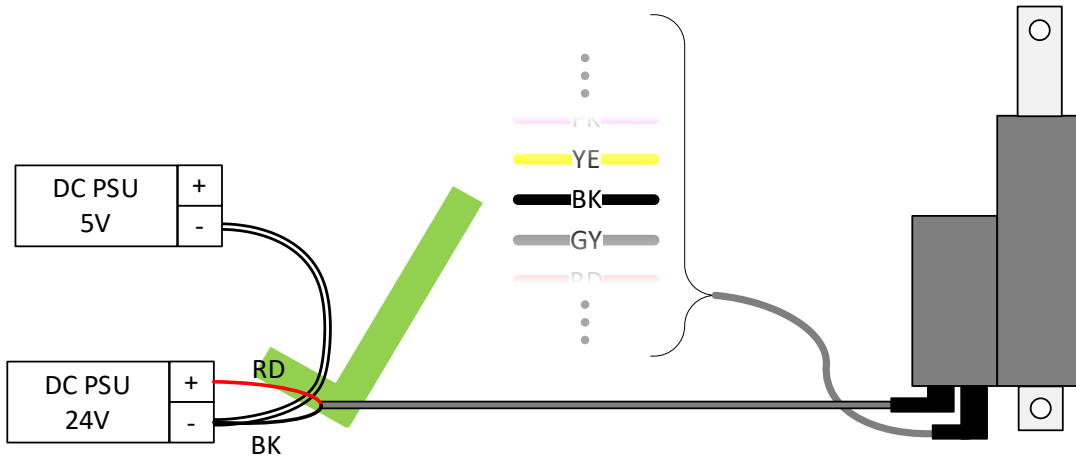

GND concept not permitted

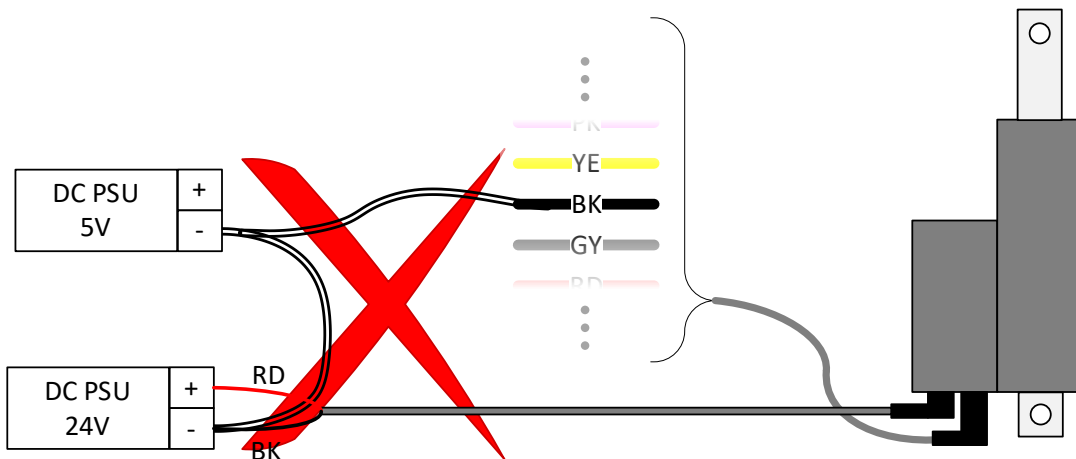

Connection AP.4.017900S (S=Slave)

Pin assignment

OUT: M12-5 pin
(top view)

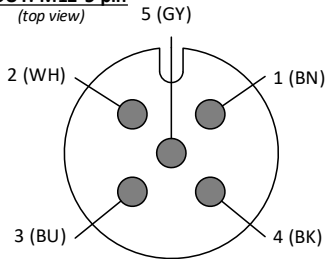

M12power
(top view)

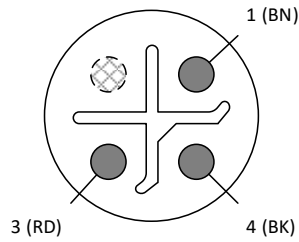

IN: M12-5 pin
(top view)

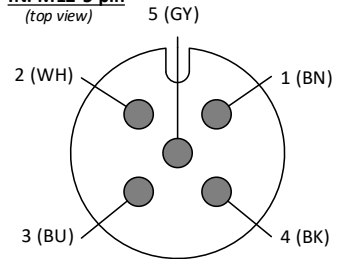

Pin assignment M12power (3-pin)

*** Supply voltage ***

Pwr

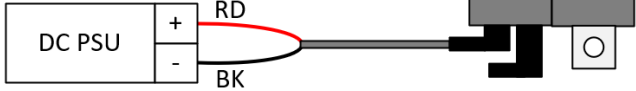
Pin	Description	
Pin 1 Brown (BN)	Do not connect	<p>V C supply voltage The power cable is used to supply the linear drive with power from the DC supply voltage (DC PSU).</p> <p>Connection Connect the black wire to minus (0V) and the red wire to plus. The permissible voltage can be found on the type plate.</p> 
Pin 3 Red (RD)	DC power supply	
Pin 4 Black (BK)		

Pin assignment M12 (5-pin) - IN

*** **Communication plug (internal)** ***

IN

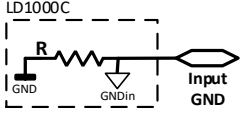
Pin	Description	
Pin 1 Brown (BN)	CAN low	CAN communication interface Interface for control, query, update, and parameterization of the linear drive.
Pin 2 White (WH)	CAN high	
Pin 3 Blue (BU)	Do not connect Internal signals.	
Pin 4 Black (BK)		
Pin 5 Grey (GY)	Input GND Common zero potential of the inputs. You can connect this wire with Output GND of the master or slave.	
		
Note: Ensure an identical GND potential for all CAN BUS nodes.		
Note: Connect this connector direct and complete with all five pins to the output connector (OUT) of the previous master or slave.		

Pin assignment M12 Signal (5-pin) - OUT

*** **Communication plug (internal) – Slave** ***

OUT

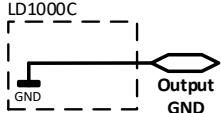
Pin	Description	
Pin 1 Brown (BN)	CAN low	CAN communication interface Interface for control, query, update, and parameterization of the linear drive.
Pin 2 White (WH)	CAN high	
Pin 3 Blue (BU)	Do not connect Internal signals.	
Pin 4 Black (BK)		
Pin 5 Grey (GY)	Output GND Common zero potential of the outputs. You can connect this wire with the Input GND of the next slave.	
		
Note: Ensure an identical GND potential for all CAN BUS nodes.		
Note: All five pins of this connector are to be connected direct and complete with all five pins to the connector IN of the next slave.		

Note: After each new cabling of a synchronization system, first perform an initialization (see installation instructions).

Connection AP.4.017910

Pin assignment

M12power
(top view)

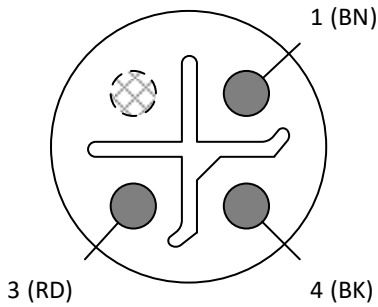

M12-12pol
(top view)

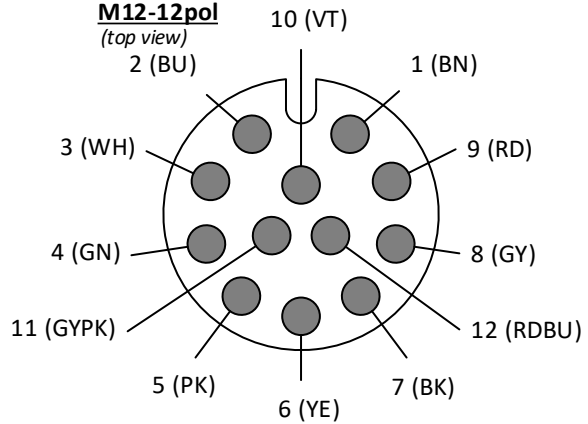

Pin assignment M12power (3-pin)

*** Supply voltage ***

Pwr

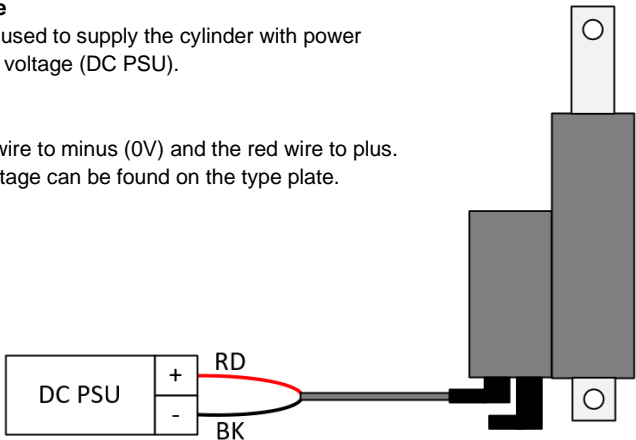
Pin	Description	
Pin 1 Brown (BN)	Do not connect	<p>V C supply voltage The power cable is used to supply the cylinder with power from the DC supply voltage (DC PSU).</p> <p>Connection Connect the black wire to minus (0V) and the red wire to plus. The permissible voltage can be found on the type plate.</p> 
Pin 3 Red (RD)	DC power supply	
Pin 4 Black (BK)		

Pin assignment M12 Signal (12-pin)

*** Communication & control plug ***

In

Pin	Description	
Pin 1 Brown (BN)	Voltage output	Fused supply voltage for switching the digital inputs on this plug. Any other use is not permitted.
Pin 2 Blue (BU)	Signal GND	CAN communication interface Interface for control, query, update and parameterization of the cylinder. Signal GND is capacitively and ohmically coupled with the GND of the cylinder to avoid critical cross currents. Note: Ensure an identical GND potential for all CAN BUS nodes.
Pin 3 White (WH)	CAN high	
Pin 4 Green (GN)	CAN low	
Pin 5 Pink (PK)	Output 4	Digital outputs The actuator indicates when the retracted and extended end positions have been reached with a separate pin each. The output is designed for switching small loads such as relays, magnetic valves or signal lamps. The internal resistor R is connected to the cylinder supply voltage Vdd (e.g. 24V) and allows for example the direct operation of common signal LEDs without separate series resistor. Specification <ul style="list-style-type: none"> • R = 2.4k Ω • V_{DS} = 0...30 V_{DC} • I_{DS} = 0...300m A Definition <ul style="list-style-type: none"> • Output 3 Retracted • Output 4 Extended
Pin 6 Yellow (YE)	Output 3	

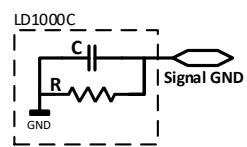
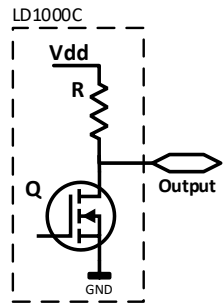

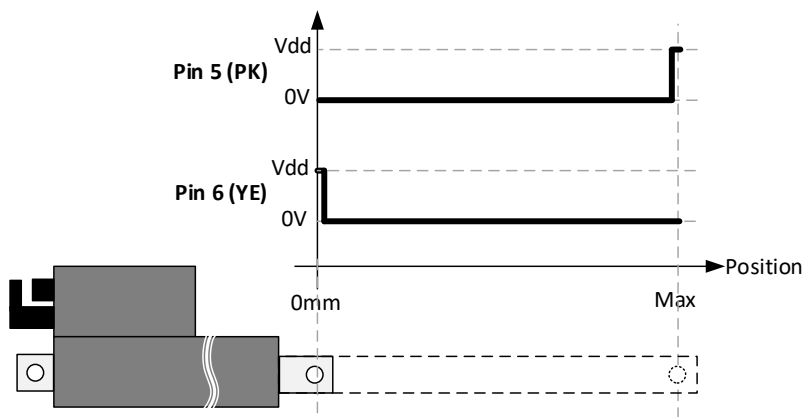
Continued on next page

<i>Continued from previous page</i>		
<p>Pin 7 Black (BK)</p>	<p>Output GND Common zero potential of the outputs (see pin 5 and 6).</p> <p>Do not connect the wire to the minus of the cylinder supply voltage (see M12power, pin 4). The cylinder could be damaged by the cross currents that can occur.</p> <p>This line is necessary only if the control unit has a galvanically isolated supply to the cylinder.</p>	
<p>Pin 8 Grey (GY)</p>	<p>Input GND Common zero potential of the inputs.</p> <p>Connecting this wire is recommended at input voltage levels below 5V. Therefore, the voltage drop on the negative wire (M12power, pin 4) has an nearly insignificant impact on the input signal.</p> <p>Connection of this wire to a control unit galvanically isolated from the LD1000 supply voltage (M12power) is required.</p>	
<p>Pin 9 Red (RD)</p>	<p>Input 3</p>	<p>Digital Inputs The digital inputs allow you to extend and retract the actuator, as well as to select other operating modes (see assembly instructions).</p> <p>The actuator allows passive and active control. For passive control, connect the brown wire (pin 1) to the corresponding input (see diagram opposite). This can be done, for example, via a manual switch (accessory), pushbutton or relay contacts.</p> <p>In the case of active control, connect the inputs to the cylinder voltage, for example. The low "high" level also allows control with a 3.3V controller.</p>
<p>Pin 10 Violet (VT)</p>	<p>Input 2</p>	
<p>Pin 11 Gray-Pink (GYPK)</p>	<p>Input 1</p>	<p><u>Configuration</u></p> <ul style="list-style-type: none"> • [Input 1] Retract • [Input 2] Extend • [Input 3] No function defined <p><u>Specification</u></p> <ul style="list-style-type: none"> • U = 0 ... 30Vdc* • Level definition <ul style="list-style-type: none"> ○ [high] ≥ 3V* ○ [low] < 0.8V* • Typical current consumption per input: 5mA <p>*Reference to "Input GND"</p>
<i>Continued on next page</i>		

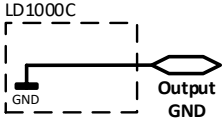
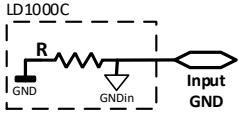
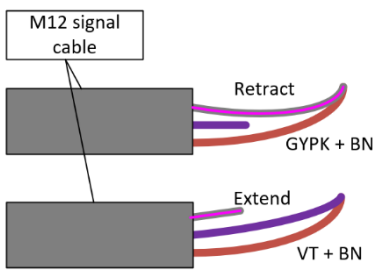
Continued from previous page

Pin 12
Red-Blue (RDBU)

Output analog (Position of the actor)

The LD1000C generates a linear output voltage depending on the current position.

Specification

- Load $R_L \geq 1k \Omega$

Output level for 12V cylinder

- **[0.5V*]** Retracted position
- **[4.5V*]** Extended position

Output level for 24V cylinder

- **[2V*]** Retracted position
- **[10V*]** Extended position

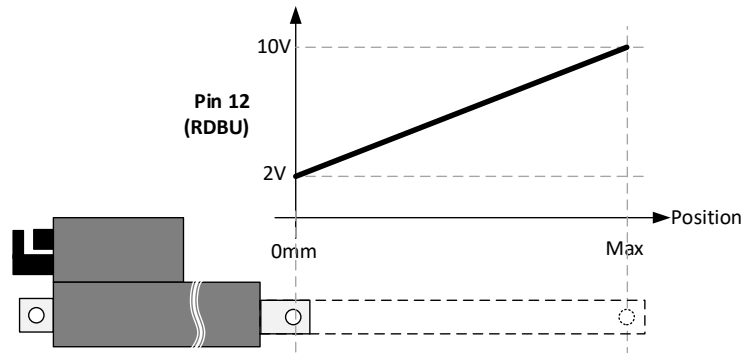
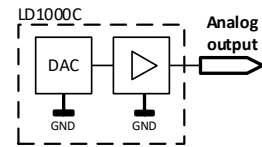

*Reference to "Output GND"

Example

Connection example – drive – passive

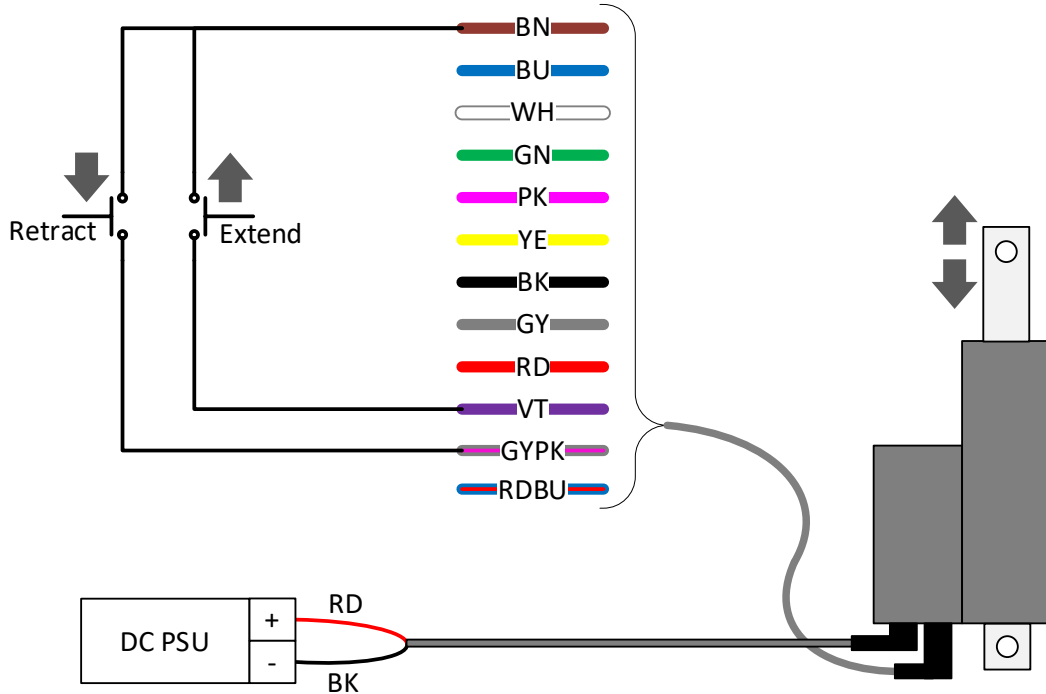

Connection example – drive – active

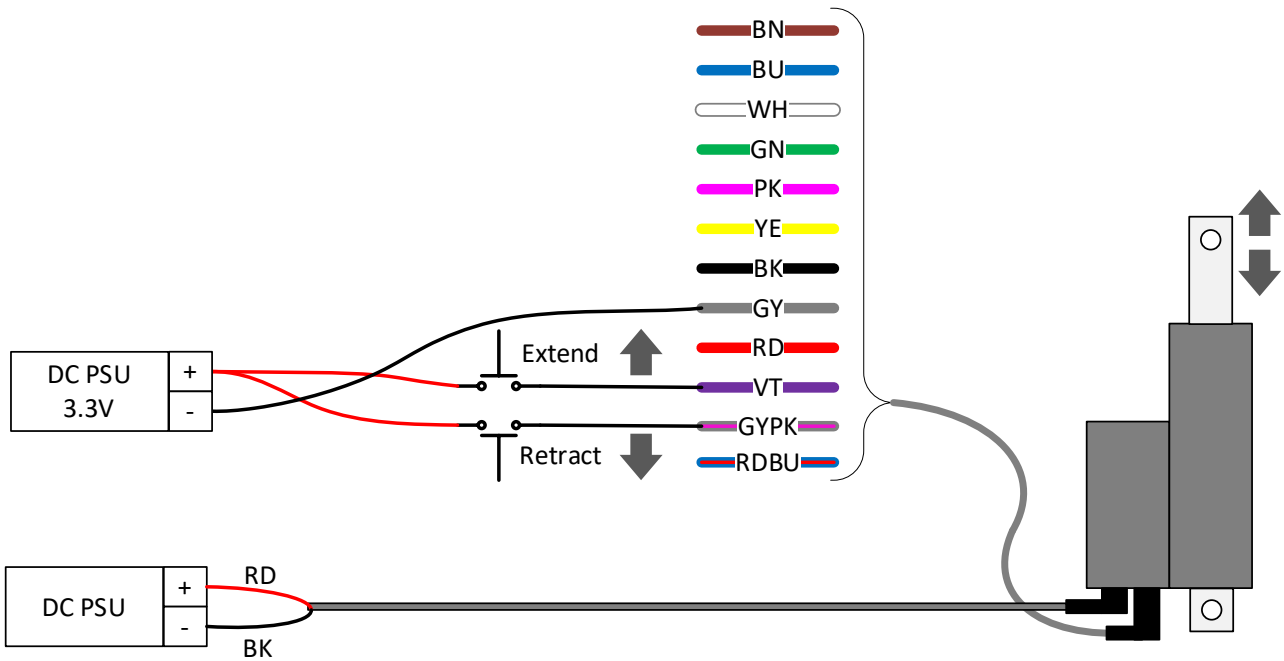

Connection example – Feedback signal

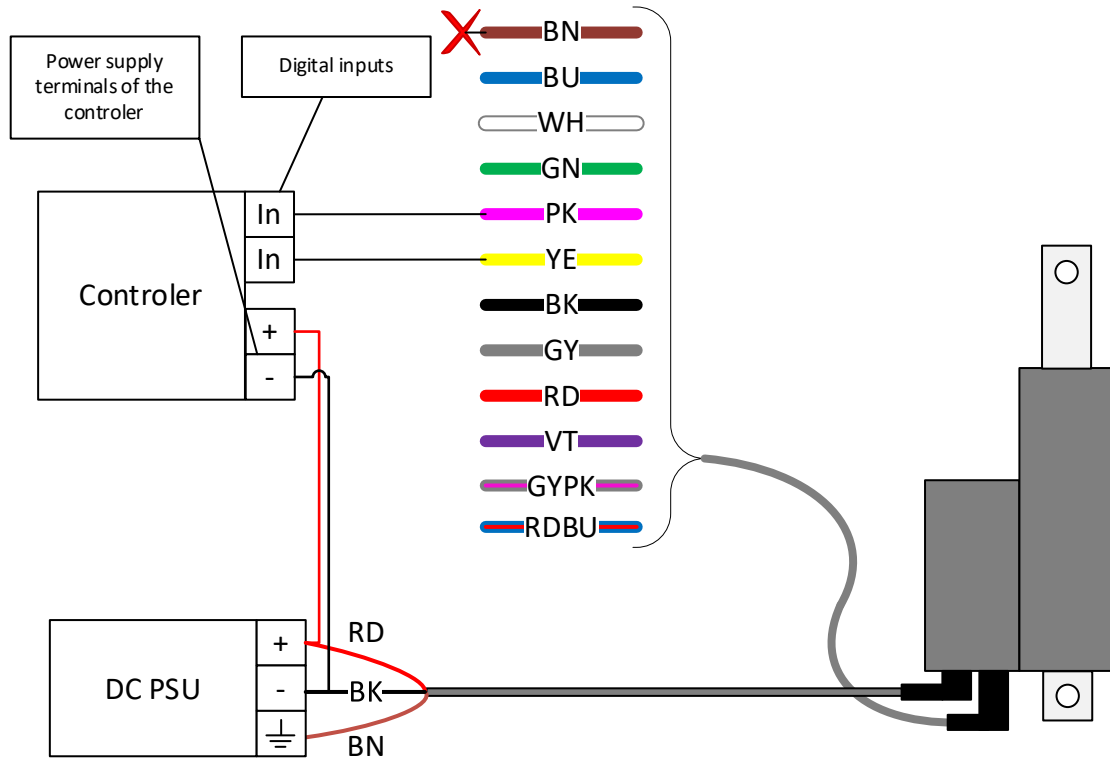

Note: The figure shows a usual application in which the control unit is connected to a central GND (minus), as is also the cylinder. The brown wire (GND) of the 12-pole cable is not allowed to be connected in this constellation.

Connection example – CAN

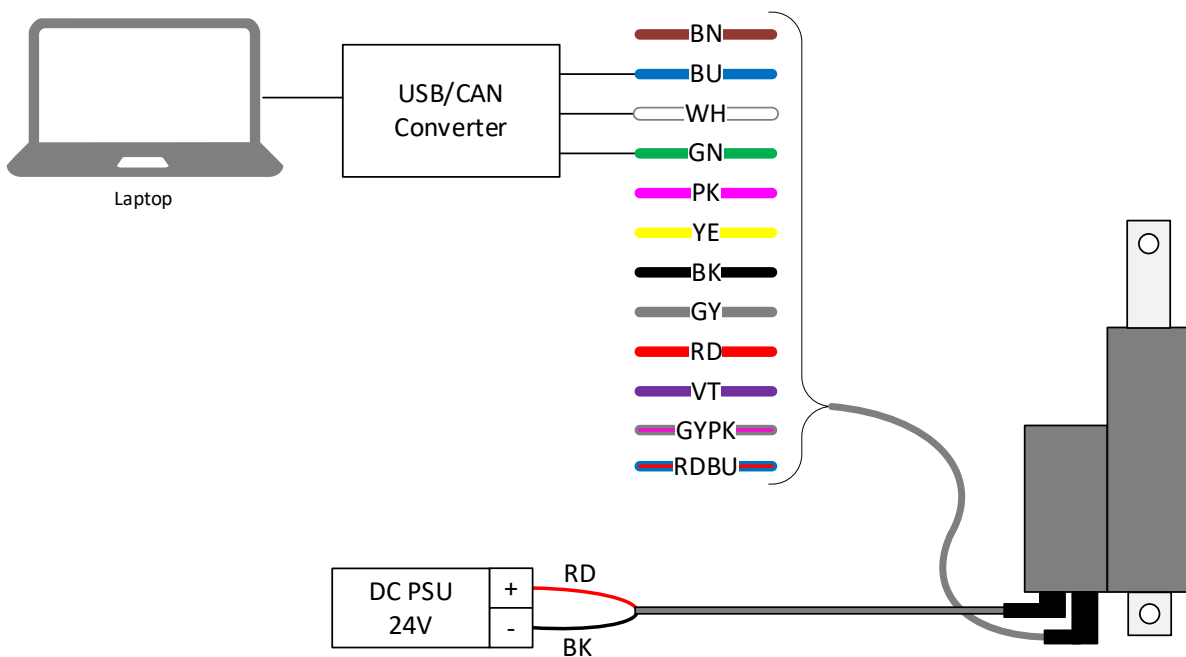

Connection example – Switch a relay

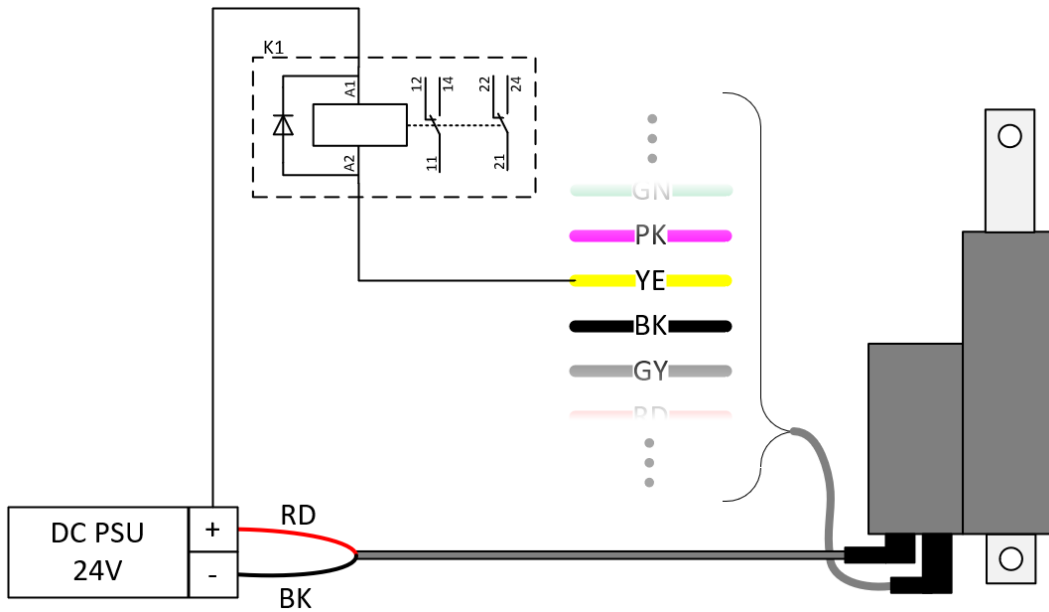

K1: Relay with integrated free-wheeling diode (Wago, 788-312)

Note: For a better overview, only one relay is shown at output 3.

Connection example – Relay with two galvanic isolated power supply units

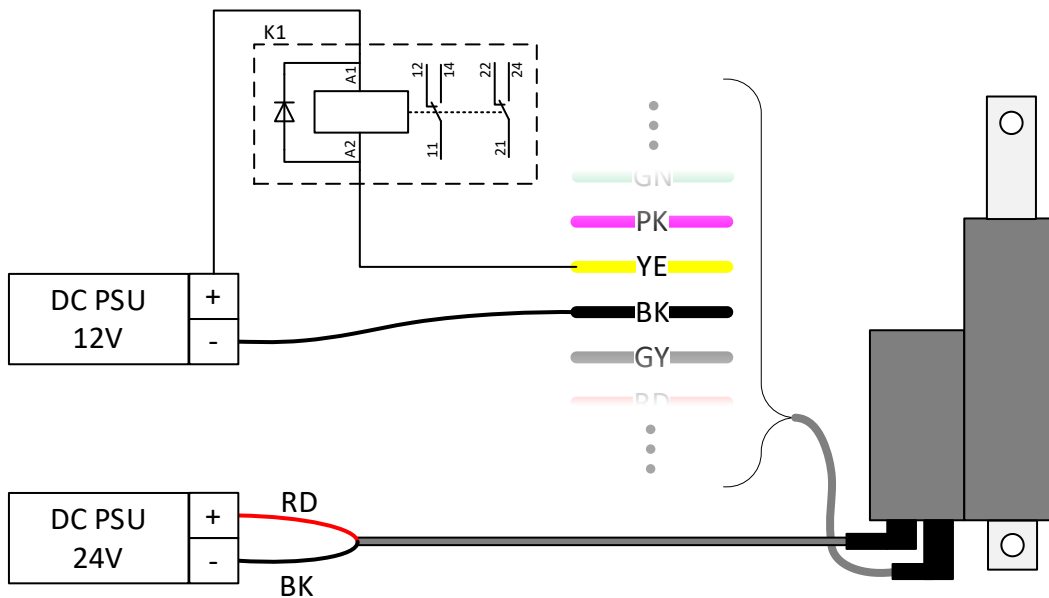

K1: Relay with integrated free-wheeling diode (Wago, 788-312)

Note: For a better overview, only one relay is shown at output 3.

Output Ground (GND) Concepts

GND concept with two separate power supplies

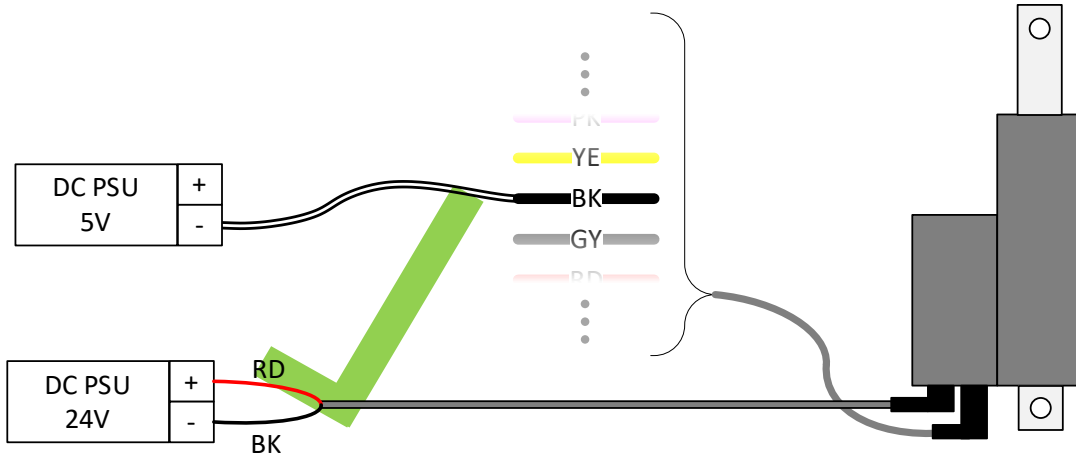

GND concept with two power supplies and common GND

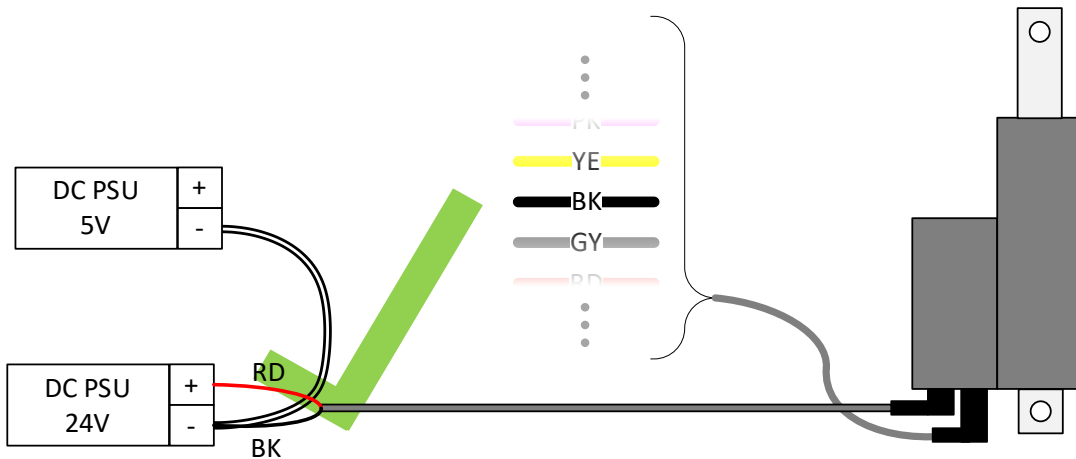

GND concept not permitted

