

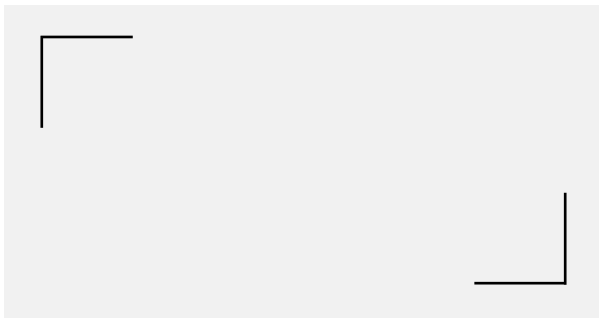

EN Assembly Instructions
Electric cylinder assemblies M9 / 010 / 015**31**



1. Declaration of incorporation	
1.1 Declaration of incorporation BGR. M9 / 010 / 015	33
2. General notes	
2.1 Notes on these assembly instructions	35
3. Liability/Warranty	
3.1 Liability	36
3.2 Product monitoring	36
3.3 Language of the assembly instructions.....	36
3.4 Copyright.....	36
4. Use/Operators	
4.1 Intended use	37
4.2 Improper use.....	37
4.2.1 Reasonably foreseeable misuse	37
4.3 Who may use, install and operate this electric cylinder	37
5. Safety	
5.1 Safety instructions	38
5.2 Special safety instructions	39
5.3 Safety signs	39
6. Product information	
6.1 Mode of operation	40
6.2 Electric cylinder assembly M9.....	40
6.2.1 Dimensions	40
6.2.2 Characteristic data of the basic version	41
6.2.3 Electrical connecting diagram.....	41
6.2.4 Overview.....	42
6.2.5 Lifting force and speed	42
6.2.6 Switching frequency.....	43
6.2.7 End position limiting.....	43
6.2.8 Overcurrent protection	43
6.2.9 Other options.	43

Table of Contents

6.3 Electric cylinder assemblies 010	44
6.3.1 Dimensions	44
6.3.2 Characteristic data of the basic version	45
6.3.3 Electrical connecting diagram	45
6.3.4 Overview	46
6.3.5 Lifting force and speed	46
6.3.6 Switching frequency	47
6.3.7 End position limiting	48
6.3.8 Setting the lifting length	48
6.3.9 Other options	49
6.3.10 Accessories	49
6.3.11 Installation position	50
6.3.12 Other technical possibilities	50
6.4 Electric cylinder assemblies 015	51
6.4.1 Dimensions	51
6.4.2 Characteristic data of the basic version	52
6.4.3 Electrical connecting diagram	52
6.4.4 Overview	53
6.4.5 Lifting force and speed	53
6.4.6 Switching frequency	54
6.4.7 End position limiting	55
6.4.8 Installation position	55
6.4.9 Overrun after switching off and repetition accuracy	56
6.4.10 Other technical possibilities	56
6.5 Limit switch	56
7. Life phases	
7.1 Electric cylinder scope of delivery	57
7.2 Maintenance	57
7.3 Important information on installation and putting into operation	57
7.4 Installation	58
7.5 Electric cylinder maintenance	58
7.6 Cleaning	59
7.7 Disposal and return	59

1. Declaration of incorporation

1.1 Declaration of incorporation BGR. M9 / 010 / 015

As set out in Machinery Directive 2006/42/EC, Annex II, 1.B for partly completed machinery

<p>The manufacturer Phoenix Mecano Komponenten AG Hofwisenstrasse 6 CH-8260 Stein am Rhein</p>	<p>The person in the community that is authorised to compile the relevant technical documents: Timo Fluck Phoenix Mecano Komponenten AG Hofwisenstrasse 6 CH-8260 Stein am Rhein</p> <p>Authorised representative: Phoenix Mecano Komponenten AG Hofwisenstrasse 6 CH-8260 Stein am Rhein</p>
<p>confirms that the named product</p>	

<i>Product/manufacture:</i>	M9, M10, LH10, LH11, LH950, LH15
<i>Project number: Trade</i>	See type plate label
<i>name:</i>	E-cylinder M9, M10, LH10, LH11, LH950, LH15
<i>Function:</i>	Extending and retracting the push rod by electromotive power to create a linear movement

complies with the requirements for partly completed machinery in accordance with EC Machinery Directive 2006/42/EG.

The following basic requirements of Machinery Directive 2006/42/EC are fulfilled:

1.1.5, 1.3.2, 1.3.3, 1.3.7, 1.3.8, 1.3.9, 1.5.1, 4.1.2.3, 1.3.4

Moreover, we declare that the special technical documents have been created according to Appendix VII Part B.

The manufacturer declares explicitly that the partially completed machinery meets all the relevant provisions of the following EC directives and ordinances:

2011/65/EC	<p>Directive 2011/65/EC of the European Parliament and of the Council from June 8th, 2011 on the restriction of the use of certain hazardous substances in electrical and electronic equipment. June 2011 on the restriction of the use of certain hazardous substances in electrical and electronic equipment Published in L 174/88 from 01/07/2011</p>
------------	--

1. Declaration of incorporation

Sources for the applied harmonised standards according to article 7, paragraph 2:

EN ISO 12100:2010-11 Safety of machinery – General principles for design – Risk assessment and risk reduction (ISO 12100:2010)

The manufacturer or the person authorised are obliged to hand over the special documents for the partially completed machine to the national authorities on reasoned request. This transfer is carried out in agreement, in electronic or paper format.

The commercial protective rights remain unaffected by this.

Important note! The partially completed machine must not be put into operation, until, if required, it has been determined that the machine in which the partially completed machine is to be installed complies with the regulations of this guideline.

Stein am Rhein / 13/07/2017

Location / Date



Signature

Technical Manager

Signatory's position

Stein am Rhein / 13/07/2017

Location / Date



Signature

Managing Director

Signatory's position

2.1 Notes on these assembly instructions

These assembly instructions are documentation which is only valid for the electric cylinder described and are intended for the manufacturer of the end product into which this partly completed machinery is to be installed.

We wish to explicitly point out that the manufacturer of the end product must produce operating instructions for the end user containing all the functions and hazard warnings of the end product.

This also applies to installation in a machine. In this case, the manufacturer of the machine is responsible for the relevant safety devices, checks, monitoring potential crushing and shearing points and the documentation.

These assembly instructions will help you

- to avoid hazards,
- to prevent downtime,
- and to guarantee and increase the lifetime of this product.

Hazards warnings, safety regulations and the information in these assembly instructions are to be observed at all times.

These assembly instructions must be read and applied by everyone who works with the product.

Commissioning is forbidden until the machine complies with the provisions of EC Directive 2006/42/EC (Machinery Directive). Before bringing onto the market, this must comply with the CE Directives, including documentation.

We hereby inform any re-user of this partially completed machine/partial machine/machine parts explicitly of its obligation to expand and complete this documentation. In particular, when installing or attaching electrical components and/or drives, the re-user is to complete a CE declaration of conformity.

Our declaration of incorporation becomes invalid automatically

3. Liability/Warranty

3.1 Liability

Phoenix Mecano Komponenten AG does not accept any liability for damage or impairments which occur as a result of changes to the construction of this electric cylinder by third parties or changes to its protective equipment.

Only original spare parts may be used when undertaking repair and maintenance. Repairs must only be carried out by trained specialist personnel.

Phoenix Mecano Komponenten AG does not accept any liability for spare parts that have not been tested and approved for use by Phoenix Mecano Komponenten AG. The EC declaration of incorporation will otherwise become invalid.

Safety-relevant devices must be inspected at regular intervals, but at least once a year, for proper function, damage and completeness.

We reserve the right to make technical changes to the electric cylinder and to these assembly instructions.

Advertising, public statements or similar announcements may not be used as a basis for the quality and suitability of the product. Claims to Phoenix Mecano Komponenten AG regarding the availability of earlier versions or adaptations to the current version of the electric cylinder will not be accepted.

In the event of any questions, please state the details on the type plate.

Our address:

Phoenix Mecano Komponenten AG
Hofwisenstrasse 6
CH-8260 Stein am Rhein
Switzerland

Tel.: +41 (0) 527427500

Fax: +41 (0) 527427590

3.2 Product monitoring

Phoenix Mecano Komponenten AG offers you state of the art products compliant with current safety standards.

Please inform us immediately if you experience repeated failures or faults.

3.3 Language of the assembly instructions

The original version of these assembly instructions was produced in the official EU language used by the manufacturer of this partially completed machine.

Translations into other languages are translations of the original version and the legal provisions of the Machinery Directive apply to these.

3.4 Copyright

Individual reproductions, e.g., copies and printouts, may only be made for private use. The production and distribution of further reproductions is permitted only with the explicit approval of Phoenix Mecano Komponenten AG. The user is personally responsible for complying with statutory regulations and may be liable for prosecution in the event of misuse.

The copyright to these assembly instructions is held by Phoenix Mecano Komponenten AG.

4.1 Intended use

The electric cylinder is to be used exclusively for the adjustment of guided components or other movement applications of a similar nature.

The electric cylinder may not be used in areas with a potentially explosive atmosphere or in direct contact with foodstuffs, pharmaceutical or cosmetic products.

Catalogue information, the contents of these assembly instructions and/or conditions determined in the order are to be taken into account.

The values given in these assembly instructions are maximum values and must not be exceeded.

4.2 Improper use

“Improper use” means that the information given in section *Intended use* is not being observed. In the event of improper use, incorrect operation and if this electric cylinder is used, installed or operated by untrained personnel, this electric cylinder may pose risks for the personnel.

Moving persons with this electric cylinder, for example, is an example of improper use and is forbidden.

In event of improper use, Phoenix Mecano Komponenten AG is no longer liable for this electric cylinder and its general operating licence will expire.

4.2.1 Reasonably foreseeable misuse

- Overloading the appliance by exceeding the weight or duty cycle
- Use in areas outside the specified IP protection class.
- Use in an environment with high air humidity > dewpoint
- Use in rooms with with a potentially explosive atmosphere as defined in the ATEX directive Use with damaged feed lines or housing
- Use when the electric cylinder is not sufficiently fixed. Moving
- up to the stop.
- Use when the push rod inside is rotated Use
- outdoors
- Use when forces or torque act laterally

4.3 Who may use, install and operate this electric cylinder

Persons who have read and understood all of these assembly instructions are permitted to use the electric cylinder, install it and operate it. The responsibilities for dealing with this electric cylinder must be clearly defined and adhered to.

5. Safety

5.1 Safety instructions

Phoenix Mecano Komponenten AG has built this electric cylinder according to the current state of the art and existing safety regulations. Nonetheless, this electric cylinder can pose risks to persons and property if it is used improperly or for a non-intended use or if the safety instructions are not observed. Correct operation guarantees high performance and availability of this electric cylinder.

Faults or conditions which can impair safety are to be rectified immediately.

Every person who is involved in the assembly, use or operation of this electric cylinder must have read and understood these assembly instructions.

This includes

- understanding the safety instructions in the text and
- being familiar with the arrangement and function of the various operating and application options.

Only nominated persons may use, install and operate the electric cylinder. All work on and with the electric cylinder may only be carried out in accordance with these instructions. For this reason, these instructions must always be kept in a location near the electric cylinder and stored safely.

The general, national and company safety regulations must be observed. Responsibilities for the use, assembly and operation of this electric cylinder must be clearly stipulated and observed so that no unclear situations can arise with regards to safety aspects. The operator must always ensure that no person or object remains in the danger area around the electric cylinder before putting into operation. The user must only use the electric cylinder if it is in perfect condition. Any change is to be reported to the nearest line manager immediately.

5.2 Special safety instructions

- All work with the electric cylinder may only be carried out in accordance with these instructions.
- The device may only be opened by authorized specialist personnel. If there is a fault in the electric cylinder, we recommend contacting the manufacturer and/or sending the electric cylinder to be repaired.
- Before installation, removal work, maintenance or troubleshooting, disconnect the power source.
- The correct routing of supply lines prevents this application from being a risk. Use original accessories and spare parts only.
- Possible damage from failure of the limit switch or from a nut breaking must be prevented in a constructive manner.
- No lateral forces or torques may affect the push rod or electric cylinder.
- With tensile loading, constructional measures must be net to prevent the push rod from releasing from the spindle.
- Unauthorised modifications or changes to the electric cylinder are not permitted for safety reasons.
- The performance specifications of these electric cylinder specified by Phoenix Mecano Komponenten AG must not be exceeded.
- The type plate must remain legible. It must be possible to identify the ratings data effortlessly at any time.
- Safety-relevant hazard symbols identify danger areas on the product.
- Safety-relevant devices must be inspected at regular intervals, but at least once a year, for proper function, damage and completeness.
- With an overhead installation of the electric cylinder, fixed loads must be secured against falling down. The danger area underneath the application must be marked in the documentation of the end product.
- If a mains lead and/or feed line is damaged. the electric cylinder is to be taken out of service

5.3 Safety signs

The warning and mandatory signs are safety signs that warn of risk or danger. Information in these assembly instructions on particular hazards or situations on the electric cylinder must be observed, as failure to do so increases the risk of accidents.



The "General mandatory sign" instructs you to be alert. Marked information in these assembly instructions requires your particular attention. They contain important information about functions, settings and procedures. Failure to observe may lead to personal injury and malfunctions to the electric cylinder or damage to the environment

6. Product information

6.1 Mode of operation

The electric cylinder is to be used exclusively for the adjustment of guided components or other adjustment tasks of a similar nature. The drive is carried out using the integrated DC motor.

6.2 Electric cylinder assembly M9

6.2.1 Dimensions

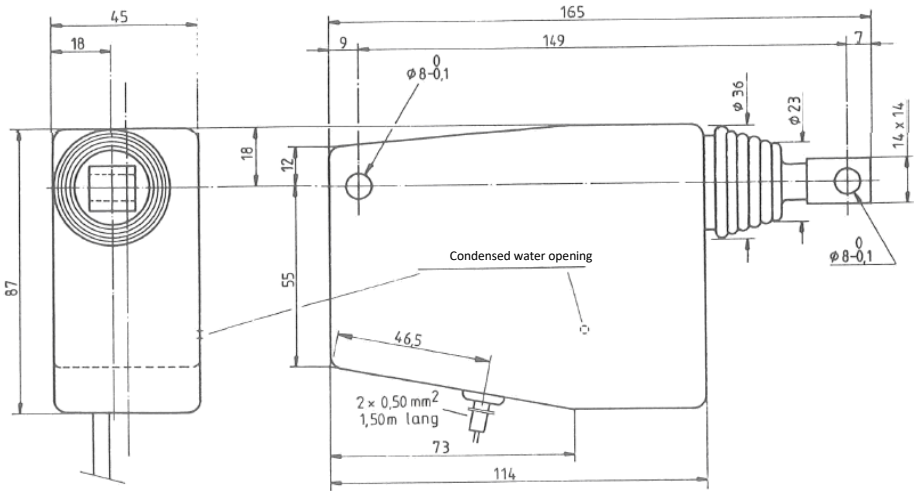

The plastic joint head is screwed onto the M8 thread of the push rod.

The plastic joint head can be pulled out by approx. 1 mm to 1.5 mm to extend the fitting length.

Use Loctite 496 adhesive for securing the screw connections.

Observe the details of the manufacturer for the application of the adhesive used.

6. Product information

6.2.2 Characteristic data of the basic version

Component	M9		
	M999	M999.1	M999.2
Type	M999	M999.1	M999.2
Standard electric connection	24 VDC		
Power consumption	15 Watt		
Dynamic tension and compression force	300 N	125 N	300 N
Static tension and compression force	500 N		
Max. lifting length with standard version	50 mm		
Lifting speed approx.	5 mm/s	14 mm/s	2 mm/s
Limit switch-off	by integrated limit switch		
Overheat protection	installed		
Connecting cable	2-wire PN. length: 1.5 m		
Protection class	IP 30		
Ambient temperature	-10 deg. Celsius to +40 deg. Celsius		
Weight	0.4 kg		
Electrical connecting diagram	SC. 4.53		
Attachments, housing side	Axis bores $\varnothing 8^{+0}_{-0,1}$ mm		
Attachments, push rod side	Joint head $\varnothing 8^{+0}_{-0,1}$ mm		
Maintenance	Maintenance-free		

6.2.3 Electrical connecting diagram

Standard configuration according to diagram SC.4.53.

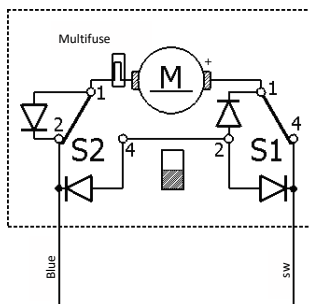

6. Product information

6.2.4 Overview

The electric cylinder of assembly M9 is available for 12 Volt and 24 Volt direct current.

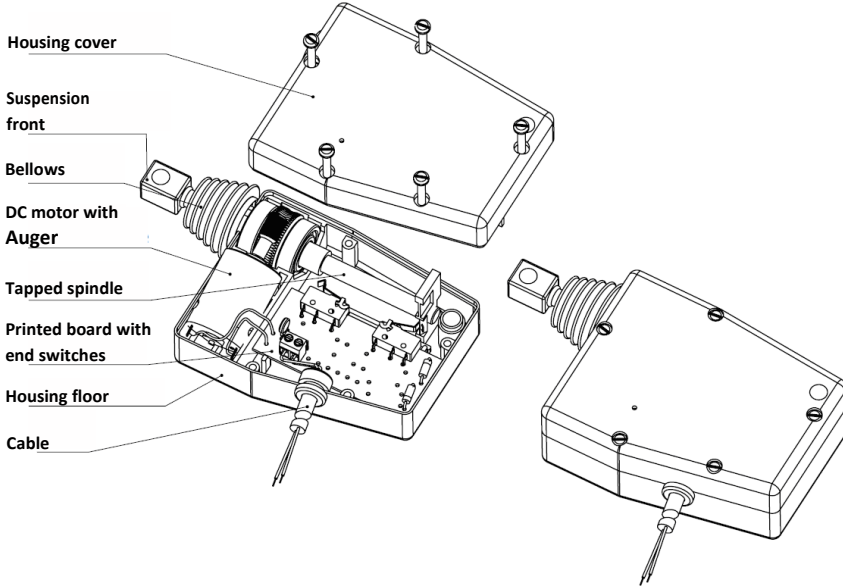

6.2.5 Lifting force and speed

The lifting force and speed of the electric cylinder assembly M9 with operating voltage 24 VDC.

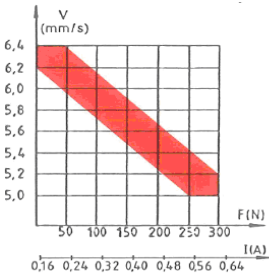

M999

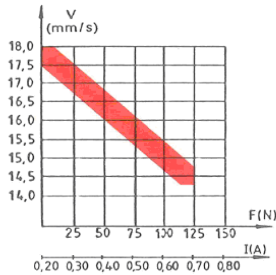

M999.1

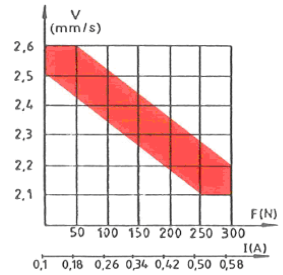

M999.2

6. Product information

6.2.6 Switching frequency

The electric cylinders of assembly M9 are not been suitable for continuous operation (100 per cent ED).

The maximum number of double strokes per hour depending on the lifting force and lifting length are specified in the table.

With ambient temperatures of +40°C or greater, the maximum permissible number of double strokes per hour is reduced by 30%.

The maximum ambient temperature must not exceed +60°C.

Component	M999	M999.1	M999.2
Lifting speed	5 mm/s	14 mm/s	2 mm/s
Nominal lifting force	300 N	125 N	300 N
Stroke length	Operating cycles in double strokes per hour at +20°C ambient temperature		
10 mm	250	750	100
20 mm	125	375	50
30 mm	80	250	30
40 mm	60	180	25
50 mm	50	150	20

6.2.7 End position limiting

Limit switches are installed in the electric cylinder for limiting the end position.

When commissioning, always ensure that the electric cylinder is switched off in the end position electrically via the limit switch. The electric cylinder must not be moved to the stop.

6.2.8 Overcurrent protection

The overcurrent protection installed has an internal resistance of 10^{-2} to 10^{-1} Ohm.

When heating from overload, this overcurrent protection switches the high-resistance and interrupts the electric circuit. In this case, the electric cylinder must be switched off and the error source remedied. The electric cylinder can be restarted after a cooling period of the overcurrent protection of at least 2 minutes.

6.2.9 Other options

- Voltage, 12 VDC Stroke
- length < 50 mm
- Signal contact according to diagram SC.4.45* non-isolated
- Signal contact according to diagram SC.4.50* with potential-free contacts
- Potentiometer according to diagram SC.4.67*
- Other special diagrams

* Diagrams for one-off production are not represented or documented in these instructions.

Information must be requested from the suppliers.

6. Product information

6.3 Electric cylinder assemblies 010

6.3.1 Dimensions

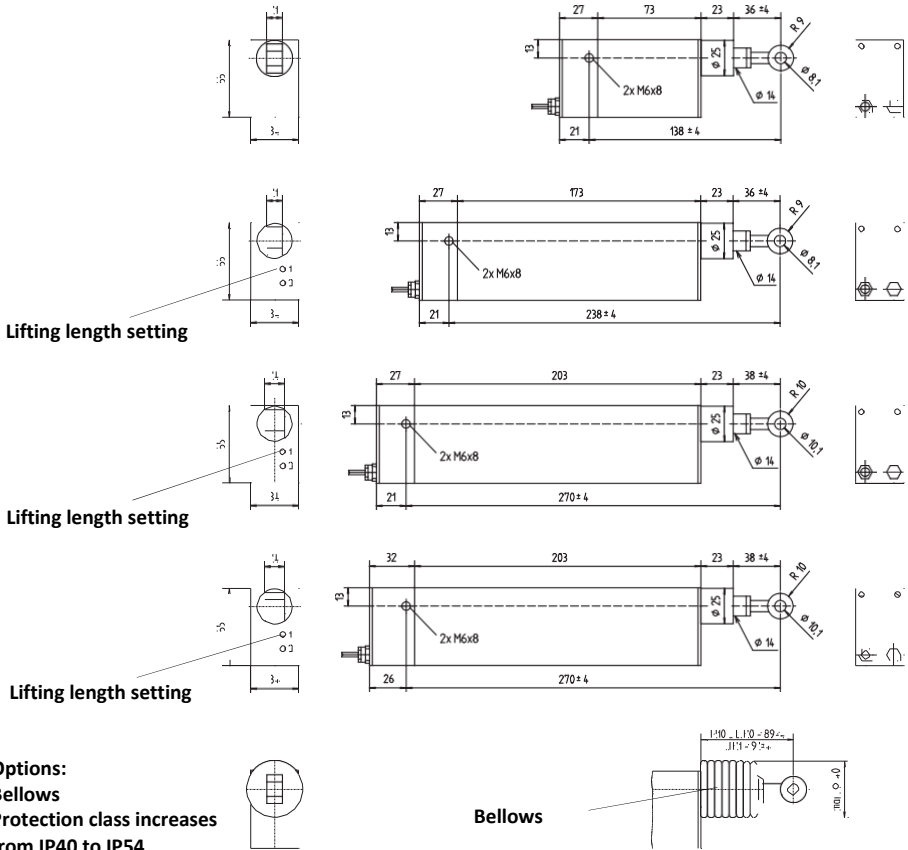

The fitting length can be adjusted ± 4 mm using the eyebolt.

After setting, the eyebolt must be secured in place using the hexagon nut (see assembly accessories).

6. Product information

6.3.2 Characteristic data of the basic version

Component	010			
Types	M10	LH10	LH11	LH950
Standard electric connection	24 VDC			
Power consumption	9 Watt		27 Watt	
Dynamic tension and compression force	200 N		300 N	500 N
Static tension and compression force	500 N			1250 N
Max. lifting length with standard version	40 mm	100 mm		
Lifting speed approx.	4 mm/s		7 mm/s	4 mm/s
Limit switch-off	Limit switch, non-adjustable	Limit switch, adjustable from outside (for lifting lengths from 30 to 100 mm)		
Overheat protection	No overheat protection			
Connecting cable	2-wire PN. length: 1.5 m			
Protection class	IP 54 for stroke ≤ 22 mm IP 40 for stroke > 22 mm	IP 54		
Ambient temperature	-20 deg. Celsius to +40 deg. Celsius		-20 deg. Celsius to +85 deg. Celsius	
Weight	0.45 kg	0.55 kg	0.75 kg	1.15 kg
Electrical connecting diagram	SC. 4.110	SC.4.23		
Attachments, housing side	Lateral trunnion mounting bore M6 x 8			
Attachments, push rod side	Eyebolt			
Maintenance	Maintenance-free			

6.3.3 Electrical connecting diagram

Standard version according to diagram SC.4.23 and SC.4.110.

SC.4.23

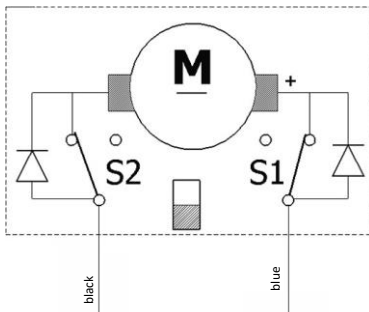

SC.4.110

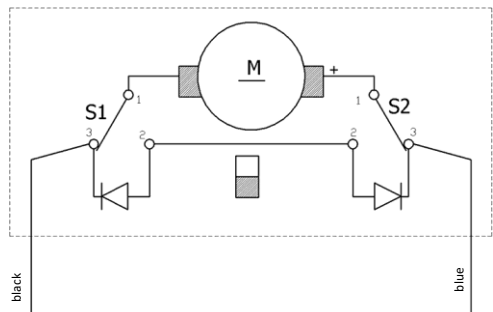

6. Product information

6.3.4 Overview

The electric cylinder of assembly 010 is available for 12 Volt and 24 Volt direct current.

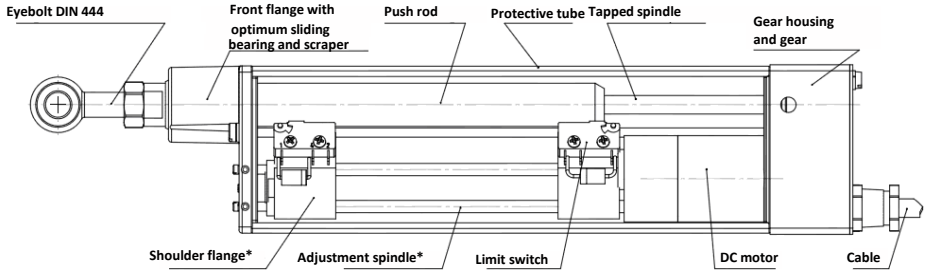

*Attention: with the electric cylinder of type M10, the stroke cannot be adjusted (without adjustment spindle and shoulder flange).

6.3.5 Lifting force and speed

The lifting forces and speeds of the electric cylinder assembly 010 are specified in the tables.

Component	010						
Type	M10/LH10						
Lifting force	Idling	40 N	50 N	100 N	150 N	200 N	300 N
Gear ratio	Approximate lifting speed in mm/s						
1:3	23	14	10	-	-	-	-
1:9	8	>	>	6	>	4	-
1:18	-	-	-	-	-	-	-
1:27	2.7	>	>	2.3	2.3	>	1.9
1:288*	constant approx. 0.25						

Component	010							
Type	LH11					LH950		
Lifting force	Idling	50 N	100 N	150 N	300 N	Idling	250 N	500 N
Gear ratio	Approximate lifting speed in mm/s							
1:3	38	31	22	-	-	-	-	-
1:9	13	>	>	10	7	-	-	-
1:18	-	-	-	-	-	7	5.5	4
1:27	-	-	-	-	-	-	-	-
1:288	-	-	-	-	-	-	-	-

* Lifting length at LH10 maximum 90 mm

6. Product information

6.3.6 Switching frequency

The electric cylinders of assembly 010 are not been suitable for continuous operation (100 per cent ED).

The maximum number of double strokes per hour depending on the lifting force and lifting length are specified in table I.

With ambient temperatures of +20 °C or greater, the maximum permissible number of double strokes per hour is reduced.

The reduced values are specified in per cent (%) in table II when considering the values from table I.

Table I

Type	M10*/LH10		LH11		LH950	
Nominal lifting force	100 N	200 N	150 N	300 N	300 N	500 N
Stroke length	Switching frequency in double strokes per hour at +20 deg. Celsius ambient temperature					
20 mm	300	150	500	250	250	150
40 mm	150	75	250	125	125	75
60 mm	100	50	160	80	80	50
80 mm	75	35	125	65	65	40
100 mm	60	30	100	50	50	30

* With type M10 maximum lifting length 40 mm

Table II

Type	M10/LH10	LH11/LH950
Ambient temperature	Reduced switching frequency compared with table I	
20 °C	100 %	100 %
40 °C	70 %	80 %
50 °C	50 %	70 %
85 °C	-	50 %

6. Product information

6.3.7 End position limiting

The electric cylinder must not be moved to the stop. Limit switches are installed as standard for limiting the end position. When commissioning, make sure that the electric cylinder is switched off in the end position electrically via the limit switch and that moving to the stop is prevented.

Electric cylinder type M 10

The limit switches are integrated and cannot be adjusted.

Special versions with lifting lengths of 40 mm or smaller are set in the factory.

Electric cylinder type LH10 / LH11 / LH950

The limit switches are integrated and can be adjusted afterwards.

Lifting length set when delivered = 100 mm

Minimum adjustable lifting length = 30 mm

Maximum adjustable lifting length = 100 mm

Adjustable lifting lengths of 0 to 70 mm are possible with special versions. Set lifting length when delivered is 70 mm.

6.3.8 Setting the lifting length

Types LH 10 / LH 11 / LH 950

Functional principle of the end position limiting:

The end of the push rod actuates the limit switch in the end position, designated as S1 and S2 in the

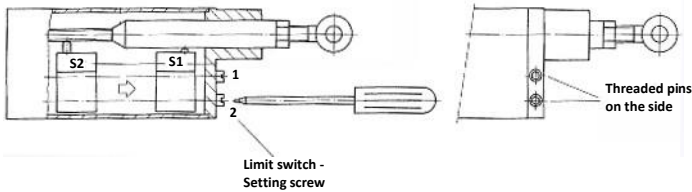

Procedure for setting the limit switch:

- turn back the threaded pin on the side
- turn the limit switch adjustment screw until the desired position (lifting length) has been reached
- re-tighten the threaded pin on the side

When turning the limit switch adjustment screw clockwise, the respective limit switch moves by 0.7 mm in the direction of the arrow per rotation.

When turning the limit switch adjustment screw counter-clockwise, the respective limit switch moves by 0.7 mm in the opposite direction of the arrow per rotation.

If the limit switches are positioned so that these make contact with one-another then the minimum lifting length is reached.

After setting the lifting length, the limit switch adjustment screws must be secured using the threaded pins on the side of the housing. Tool required: hexagon socket with 1.5 mm width across flats

6.3.9 Other options

Bellows

The electric cylinder of assembly 010 can be retrofitted with a bellows.
The overall length and the fitting length extend by 30 mm as a result of this.

With type M 10, the protection class increases from IP40 to IP54 with the bellows.

Potentiometer

The types LH10, LH11 and LH950 can be equipped with the following potentiometers:

- 10 kOhm linear potentiometer for 55 mm lifting length according to SC.4.001035
- 2 kOhm linear potentiometer for 60 mm lifting length according to SC.4.001973 1
- kOhm linear potentiometer for 90 mm lifting length

Other resistance values and lifting lengths on request.

6.3.10 Accessories

Fixing / trunnion kit assembly 010

The trunnions are screwed into the existing thread of the electric cylinder from the side.

One set comprises two trunnions. The trunnion set is not included in the scope of delivery.

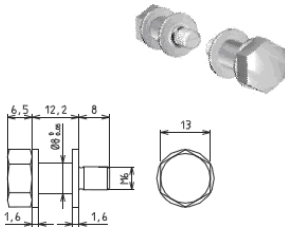

6. Product information

6.3.11 Installation position



The counter-piece must not be able to be twisted. The electric cylinder must be able to be rotated in the direction of the arrow (see graphic).

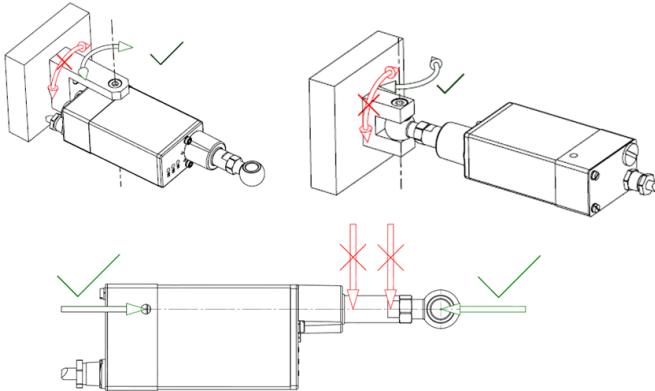

6.3.12 Other technical possibilities

- Voltage, 12 VDC
- with LH10 / LH11 / LH950, additional limit switch S3 for intermediate lifting position after SC.4.000997
- Signal contact according to diagram SC.4.45* non-isolated
- Signal contact according to diagram SC.4.50* with potential-free contacts Potentiometer
- according to diagram SC.4.67*
- Other special diagrams

* Diagrams for one-off production are not represented or documented in these instructions.

Information must be requested from the suppliers.

6. Product information

6.4 Electric cylinder assemblies 015

6.4.1 Dimensions

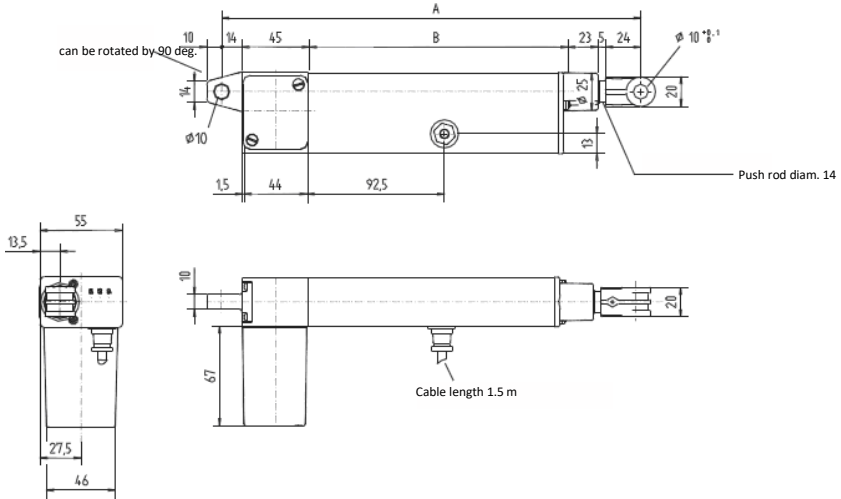

		Basic version	Module	
Standard lifting length: limit switch non-adjustable		140 mm	180 mm	300 mm
Standard lifting length: limit switch adjustable		100 mm	140 mm	260 mm
Standard design lengths:	Dimension A	284	324	444
	Dimension B	173	213	333

6. Product information

6.4.2 Characteristic data of the basic version

Component	015					
	Type lift (limit switch) non-adjustable	LH15	LH15.1	LH15.2	LH15.6	LH15.7
Type lift adjustable	LH15.3	LH15.4	LH15.5	LH15.9	LH15.10	LH15.11
Dynamic tension and compression lifting force	1000 N	600 N	300 N	450 N	200 N	60 N
Static tension and compression lifting force	2000 N	2000 N	2000 N	1000 N	600 N	300 N
Lifting speed approx.	5 mm/s	10 mm/s	22 mm/s	25 mm/s	60 mm/s	100 mm/s
Power input	approx. 2.2 A					
Power consumption	approx. 50 Watt					
Electrical connection	24 VDC					
Connecting diagram	SC.4.53					
Overcurrent protection	installed					
Protection class according to DIN 40050	IP54					
Ambient temperature	-20 deg. Celsius to + 60 deg. Celsius					
Attachments, housing side	Joint eye					
Attachments, push rod side	Swivel head					
Maintenance	maintenance-free					
Weight	approx. 1.2 kg					

6.4.3 Electrical connecting diagram

Standard version according to diagram SC.4.53.

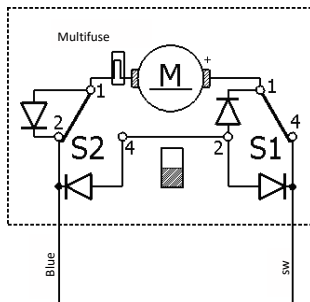

6.4.4 Overview

The electric cylinder of assembly 015 is available for 12 Volt and 24 Volt direct current.

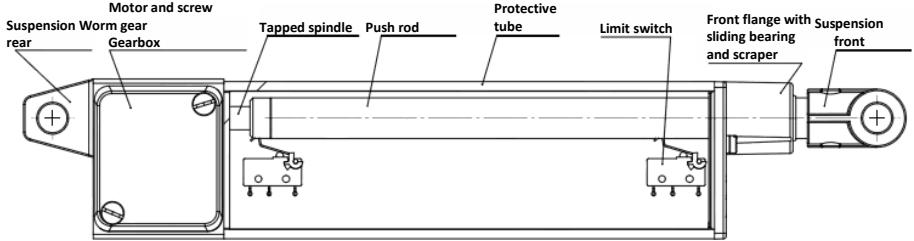

6.4.5 Lifting force and speed

The idling speed V_0 is approx. 20% greater than the nominal lifting speed V_N .

The "static lifting force" specified in the table "characteristic data of the basic version" is the force that can be applied to the drive when switched off without damaging it and is self-locking in doing so.

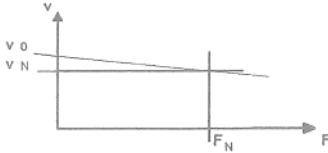

F_N =Nominal lifting force

V_N =Nominal lifting speed

6. Product information

6.4.6 Switching frequency

The electric cylinders of assembly 015 are not been suitable for continuous operation (100 per cent ED).

The maximum switching frequency /h at +20 deg. Celsius ambient temperature is calculated as follows:

$$Z = \frac{\text{Nominal lifting speed [mm/s]}}{\text{Lifting path per double stroke [mm/DH]}} \times 560 \text{ [s/h]} = \text{_____ [DH/h]}$$

- Double stroke (DH) = Feed and return run
- Switching frequency Z = max. number of double strokes per hour, equal distribution of the switching frequency for one hour at +20 deg. Celsius ambient temperature

Reduction of the switching frequency depending on the ambient temperature with regard to the value calculated at an ambient temperature of +20 deg. Celsius.

- +40 deg. Celsius or higher, the switching frequency reduces by 25 per cent
- +60 deg. Celsius or higher, the switching frequency reduces by 50 per cent
- +80 deg. Celsius or higher, the switching frequency reduces by 75 per cent

In order to limit heating by starting currents, for 60 or more switching cycles per hour a series resistance must be switched in the motor circuit.

Dimensioning the series resistance:

24 VDC version = series resistance 1 Ohm/9 Watt

12 VDC version = series resistance 0.5 Ohm/17 Watt

The series resistance reduces the intensity of the starting current.

The use of a series resistance increases the service life of the collector and carbon brushes.

The drop in current at the series resistance causes a reduction of the lifting speed by approx. 10 per cent at nominal load.

6.4.7 End position limiting

The electric cylinder must not be moved to the stop. Limit switches are installed as standard for limiting the end position.

When commissioning, make sure that the electric cylinder is switched off in the end position electrically via the limit switch, thus preventing it from moving to the stop.

Versions of the end position limiting

- Limit switches set in the factory. (LH15; LH15.1; LH15.2; LH15.6; LH15.7; LH15.8). The stroke can be set subsequently!
- Lifting lengths that can be set. (LH15.3; LH15.4; LH15.5; LH15.9; LH15.10; LH15.11). The end position limiting is set to the maximum lifting length when delivered.

Procedure for setting the limit switch

- Retract the push rod up until the end position electrically and secure in this position against twisting.
- Switch off the electric cylinder.
- Keep turning the push rod clockwise until you reach the desired new position of the end position.
- The push rod must no longer be rotated in this condition. Turning the push rod leads to the adjustment of the desired position of the end position.
- With the next motorized adjustment the push rod moves to the set position of the end position.

The different types of assembly 015 have different spindle pitches.

Turning the push rod by 180 degrees results in the following values:

- 0.625 mm path for a nominal speed of 5/10/22 mm/s
- 3.0 mm path for a nominal speed of 25/60/100 mm/s

6.4.8 Installation position

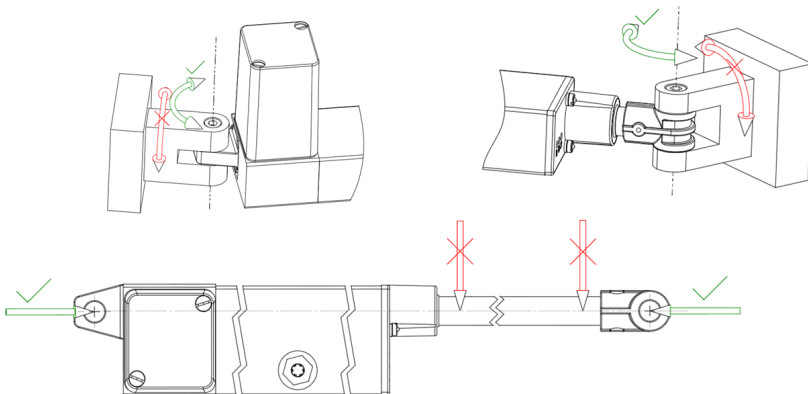

6. Product information

6.4.9 Overrun after switching off and repetition accuracy

Different overrun paths result depending on the lifting speed, load and load direction.

- Low lifting speed and high load = ≤ 1 mm
- High lifting speed and low load = ≤ 15 mm

In order to limit the overrun, we recommend you briefly short-circuit the motor after switching off. This results in a dynamic braking and much shorter overrun.

A repetition accuracy of < 1 mm can be achieved with the same load and same load and direction of motion.

In the end position, this short-circuit brake switching is carried out as standard via the limit switch.

When using with maximum lift utilisation that is defined by the set stroke of the integrated limit switch, you do not need an external short-circuit brake switching.

6.4.10 Other technical possibilities

- Voltage, 12 VDC
- Signal contact according to diagram SC.4.45* non-isolated
- Signal contact according to diagram SC.4.50* with potential-free contacts
- Potentiometer according to diagram SC.4.67*
- Other special diagrams

* Diagrams for one-off production are not represented or documented in these instructions.

Information must be requested from the suppliers.

6.5 Limit switch

The electric cylinders of the assemblies M9 / 010 / 015 are equipped with two limit switches. The limit switches prevent running over the maximum lifting length (extracted) as well as running over the lower retention point (retracted).



The electric connecting diagrams specified in this instruction must be observed under all circumstances.

An incorrect supply of current can traverse beyond the limit switches.

Failure to observe may lead to personal injury and malfunctions to the electric cylinder or damage to the environment.

7.1 Electric cylinder scope of delivery

The electric cylinder will be delivered as an individual component.
The controllers, handsets as well as accessories are not included in the scope of delivery.

7.2 Maintenance

The product is to be checked by suitable personnel for visible and functional damage. Damage caused by transport and storage must be reported to the responsible person and Phoenix Mecano Komponenten AG immediately.

Putting damaged electric cylinders into service is forbidden.

The environmental conditions for the storage of the electric cylinder apply as follows:

- No oil-contaminated air
- Contact with solvent-based paints must be avoided
- lowest / highest ambient temperature: -20 deg. Celsius / +60 deg. Celsius
- relative humidity: from 30 per cent to 75 per cent
- air pressure: from 700 hPa to 1060 hPa
- Falling below the dewpoint is not allowed

Divergent environmental factors must be approved by Phoenix Mecano Komponenten AG.

7.3 Important information on installation and putting into operation



It is essential that you note and observe the following instructions.
Otherwise persons could be injured or the electric cylinder or other components could be damaged.

- No additional holes may be made in the electric cylinder. This electric cylinder must not be used outdoors.
- The electric cylinder must be protected against the ingress of moisture.
- After setting up and putting into operation, it is essential that the plug of the power supply is freely accessible.
- The electric cylinder must not be moved to "Block". Risk of mechanical damage! The electric cylinder must not be opened.
- The user must ensure that there is no danger when the power supply is active.
- When designing applications with this electric cylinder, take care to avoid crushing and shear points. These must be respectively secured and marked.
- If a mains lead and/or feed line is damaged, the electric cylinder is to be taken out of service immediately.
- Phoenix Mecano Komponenten AG does not accept any guarantees when the customer uses their own electric circuitry, exception is with a limit switch.

7. Life phases

7.4 Installation

Check the electric cylinder for any damage after receiving it. The electric cylinder will be delivered ready for operation without a controller.

The following instructions must be observed during installation:

- When using / mounting a joint head or fork head, make sure that the heads are secured correctly using the supplied nuts.
- Perform a test run.
 -  Non observance of this procedure will lead to damage to the electric cylinder! This nullifies the guarantee!
 - With regard to the installation position of the components, take care to avoid crushing and shear points, especially when taking into consideration any future applications.

7.5 Electric cylinder maintenance

The electric cylinder generally does not require servicing, but it is not exempt from wear and tear. This means that in the case of excessive wear the safety of the product may no longer be guaranteed.

- All work with the electric cylinder may only be carried out in accordance with these instructions. The device may only be opened by authorized specialist personnel.
- If there is a fault with the drive, it must be sent to the manufacturer for repairs.
- When working on the electrics or the electrical elements, they must be first disconnected from the supply to prevent any risk of injury.
- Unauthorised modifications or changes to the electric cylinder are not permitted for safety reasons.
- Safety-related equipment must be checked on a regular basis, however, at least once a year for completeness and function.

7.6 Cleaning

You can clean the hand switch and the outside surface of the electric cylinder's profile using a lint-free, clean cloth.



Solvent-based cleaners will corrode the material and can damage it.

7.7 Disposal and return

The electric cylinder must either be disposed of in accordance with the applicable regulations and guidelines, or returned to the manufacturer.

The electric cylinder contains electronic components, cable, metals, plastics etc. and is to be disposed of in accordance with the applicable environmental regulations of the respective country.

In the European Economic Area disposal is governed by the EU Directive 2002/95/EC or the relevant national legislation.